

INSTALLATION AND OVERHAUL MANUAL

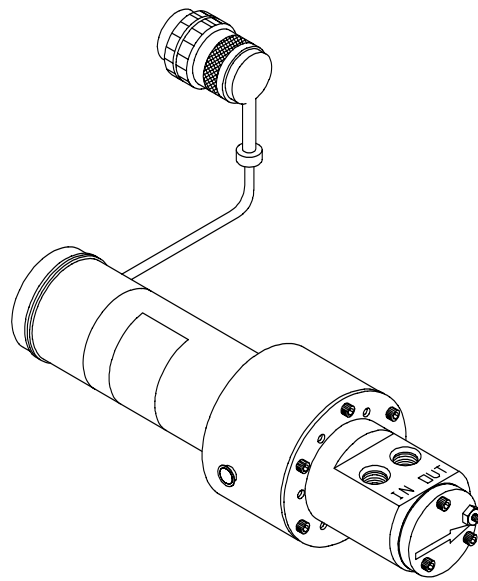

**MICROPUMP MODEL *09-31-316
COFFEE / LAVATORY PUMP
PART NUMBER 83427
(CANADAIR P/N: 601R43135-3)**

MICROPUMP, INC
A Unit of IDEX Corporation

P.O. BOX 8975
VANCOUVER, WA.
98668-8975
USA
Phone: (360) 253-2008
Fax: (360) 253-8924

**INSTALLATION
OPERATION
OVERHAUL
MANUAL P/N 7364 Rev. F
12/4/03**

TABLE OF CONTENTS

ITEM	DESCRIPTION	PAGE
1.	Introduction	3
1.1	General Description	3
1.2	Specifications	3
1.3	Marking - General	3
1.3.1	Marking - Serviced units	3
2.	Installation	4
2.1	Fitting Installation / Removal	4
2.1.1	General Fitting Installation	4
2.1.2	Clamping/Holding Pump for Fitting Installation	4
2.2	System Requirements	4
2.2.1	Pump Location in System	4
2.2.2	Fluid Requirements - Filtering	4
2.2.3	Fluid Requirements - Temperatures	4
3.	Operation	5
3.1	Pump Starting Time - New	5
3.2	System Maintenance - Filter	5
3.3	Draining of System	5
3.4	Voltage / Current to Motor	5
3.5	Pump Performance	5
3.6	Troubleshooting	5
4.	Overhaul	5
4.1	General Work Area Conditions	5
4.2	Tools Required	6
4.3	Other Supplies Required	6
4.4	Disassembly	6
4.4.1	Pump From Motor	6
4.4.2	Motor Assembly	6
4.4.3	Pump Assembly	7
4.5	Evaluation of Motor and Drive Assembly Components	8
4.6	Evaluation of Pump Assembly Components	9
4.6.1	Pump Body and End Cap	9
4.7	Cleaning of Pump Assembly Components	10
4.8	Removal and Replacement of Bushings	10
4.9	Reassembly of Pump Assembly	10
4.10	Reassembly of Motor and Drive Assembly	12
4.11	Reassembly of Pump Assembly to Motor and Drive Assembly	12

MICROPUMP INSTALLATION AND OVERHAUL MANUAL

<u>ITEM</u>	<u>DESCRIPTION</u>	<u>PAGE</u>
5.	Testing of Unit	12
5.1	Test Equipment Hydraulic	12
5.2	Test Equipment Electrical	12
5.3	Test Procedure	13
6.	Illustrated Parts Breakdown	13
6.1	Numerical Index	13
6.2	Detailed Parts List	13
6.3	How To Use Catalog	14
7.	Numerical Index	15
8.	Detailed Parts List	16
9.	Trouble Shooting Chart	17
10.	Pump/Motor Assembly Physical Specifications, Fig. 1	18
11.	General Test Setup, Fig. 2	18
12.	Pump Body Clamping Detail, Fig. 3	19
13.	Pump Body Pressure Regulator Hole Detail, Fig. 4	19
14.	Bushing Assembly Tool Detail, Fig. 5	20
15.	Motor Assembly Magnet Setting Detail, Fig. 6	20
16.	Pump Assembly Magnet Setting Detail, Fig. 7	21
17.	Top Assembly Exploded Detail, Fig. 8	21
18.	Motor Assembly Exploded Detail, Fig. 9	22
19.	Pump Assembly Exploded Detail, Fig. 10	22
20.	Bushing / Pump Body Installation Detail, Fig. 11	23
21.	Motor Specifications, Fig. 12	23
22.	Product Warranty	24

MICROPUMP INSTALLATION AND OVERHAUL MANUAL

1. Introduction

1.1 General Description

The Model *09-31-316-83427 Coffee / Lavatory pump supplies water to the coffeemaker and / or the lavatory tap. It is a gear-type water pump with a built in pressure regulated by-pass, magnetically coupled to a self-contained motor assembly. All seals are static and seal positively against leaks. The pump assembly can be drained for freeze protection.

1.2 Specifications

The chart below itemizes the hydraulic and electrical specifications for this product. See Figure 1 for physical specifications.

Pump internal wetted materials	316 S.S., Polyphenylene Sulphide, Delrin, Buna-N, P.T.F.E.
Pumping fluid	Water at 70°F (nominal)
Blocked Flow Pressure	Minimum: 35 psig, Maximum: 60 psig
Open Flow Rate	Minimum: 0.45 gpm
Flow Rate, 20 ± 1 psig	Minimum: 0.18 gpm
Flow Rate, 30 ± 1 psig	Maximum: 0.15 gpm
Voltage applied to motor	27-29 VDC
Motor load current (nominal)	1.30 amps
Motor stall current	4.75 amps
Motor continuous duty current (maximum)	1.70 amps
Filters (motor)	EMI and thermal protection built in
Weight (pump/motor assembly)	2.2 lbs maximum

1.3 Marking - General

New units will be chemically etched with the following information; Micropump part number, model number and individual serial number.

1.3.1 Marking - Serviced units

An "R" at the end of the serial number indicates the motor and / or pump has been factory rebuilt. An "S" indicates the pump has been rebuilt by an authorized service center.

MICROPUMP INSTALLATION AND OVERHAUL MANUAL

2. Installation

2.1 Fitting Installation/Removal

The pump is provided with National Pipe Threads (N.P.T.) on the inlet and outlet ports. These are tapered threads and do rely on compression to seal. Be careful not to over torque the fittings.

2.1.1 General Fitting Installation

When installing or removing fittings in the pump ports, do not clamp the unit by holding the motor or the drive housing. This may damage the motor or misalign the magnetic coupling. Also, do not thread the “out” fitting more than seven total turns into the “out” port of the pump body. Any more than seven full turns will jam the fitting against the pressure regulator piston (8) and cause the regulator to malfunction. If Teflon tape is used for thread sealant, be careful that no Teflon scraps get into the pump head.

2.1.2 Clamping/Holding Pump for Fitting Installation

If it is necessary to clamp the pump body to install or remove “in” or “out” fittings, use a vise with soft jaws or equivalent. **You must clamp it at an angle to avoid crushing the thin section at the pressure regulator hole.** See Figure 3 which illustrates the thin section area. The pressure regulator hole is precisely machined to size and roundness. Any distortion will cause regulator to malfunction or leak. A damaged pressure regulator hole cannot be repaired and the body must be replaced.

2.2 System Requirements

2.2.1 Pump Location in System

The pump should be oriented vertically (motor up) with minimum restriction on the inlet side to facilitate priming and to allow the drain valve to operate. A positive head should be provided to the inlet, such as from an overhead tank. A vent line plumbed immediately on the discharge of the pump will facilitate priming. Tubing and fitting size is recommended to be 1/4” (6mm).

2.2.2 Fluid Requirements - Filtering

Pump life is increased with fluid purity. It is recommended the pumping fluid be filtered using as fine a mesh as possible. Filter fluid to 40 micron for soft particles and 5 micron for hard particles.

2.2.3 Fluid Requirements - Temperatures

The pump should not be installed in an ambient temperature over 180°F (82°C) nor should the pump continuously see water at temperatures higher than this.

MICROPUMP INSTALLATION AND OVERHAUL MANUAL

3. Operation

3.1 Pump Starting Time - New

With all of the recommended system requirements in place, a new unit should need to run momentarily before being fully primed and operational. Under no circumstances should the unit be left to run dry for more than a few minutes, or damage may occur.

3.2 System Maintenance - Filter

A system filter should be cleaned or replaced on a regular basis to optimize life and performance. If the unit does not prime, clean filter and remove any debris from tubing or fittings.

3.3 Draining of System

Provision should be made to shut the pump off when no flow is being used to prevent overheating and undue wear. The pump should be completely drained if it is to be exposed to freezing ambient temperatures. The system should allow drainage through the inlet and outlet pump ports. This allows the drain valve (item 13, figure 10) to drain the magnet cup and prevent freeze damage.

3.4 Voltage / Current to Motor

Electrical power to the motor should not exceed the values stated in Sections 1.2 “Specifications” and 4.5 “Evaluation of Motor and Drive Assembly ” in this manual.

3.5 Pump Performance

The hydraulic performance should conform with the values stated in Sections 1.2 “Specifications” and 5. “Testing of Unit” in this manual.

3.6 Troubleshooting

To assist in determining the source of a system failure, refer to Section 9. “Troubleshooting” of this manual.

4. Overhaul

Only Micropump replacement parts should be used when servicing. A Service Overhaul kit is available from Micropump or an authorized distributor . Order part number 83490 Service Kit. This kit is unique to the Model*09-31-316 Coffee / Lavatory Pump, Part Number 83427, and is not interchangeable with other units. Overhaul of the pump can be performed by an aircraft operator if the following tools are used and the service technician has been trained by Micropump.

4.1 General Work Area Conditions

To properly service this unit the work area must be clean and free of metal particles and dust. Many of the replacement parts are small and could be lost.

4.2 Tools Required

MICROPUMP INSTALLATION AND OVERHAUL MANUAL

- 4.2.1 .050 in (1.27 mm), 3/32 in. (2.38 mm), 5/32 in. (3.97 mm) Hex Keys
- 4.2.2 3/16 in. (4.76 mm) - wide flat blade screwdriver
- 4.2.3 Bushing tool (Micropump P/N 5465)
- 4.2.4 Soft jaw vice or equivalent
- 4.2.5 #6-32 UNC thread tap and tap handle
- 4.2.6 #30 drill blank or .1283 diameter gage pin
- 4.2.7 Exacto knife and pointed blade
- 4.2.8 Dial indicator and magnetic base
- 4.2.9 Power supply (28 VDC, 3 amps maximum)
- 4.2.10 Multimeter
- 4.2.11 Optical tachometer
- 4.2.12 Torque wrench with attachments to fit the hex keys above

4.3 Other Supplies Required

- 4.3.1 Test Fixture
See Figure 2.
- 4.3.2 Stoddard Solvent fluid.
- 4.3.3 Lubricants
Use any one of the following Dow Corning silicone lubricants for greasing of the pressure regulator and gasket seal (23). Use no substitutes. The “slip-stick” characteristics of lubricants vary greatly. The use of an unlisted lubricant can cause the regulator to malfunction. Dow Corning High Vacuum Grease Silicone lubricant, C. 55M grease, Dow C. 4 grease or Dow C. 111 compound.

4.4 Disassembly

- 4.4.1 Pump From Motor
Remove the six screws (1) attaching the pump assembly (2) to the motor (3). See Figure 8.
- 4.4.2 Motor Assembly
See Figure 9. Do not damage or shorten external wiring if motor is to re-used.
 - 4.4.2.1 Remove access hole plug (32), then rotate drive magnet (28) to align setscrew (33) with access hole in drive housing (30).
 - 4.4.2.2 Loosen setscrew (33) with a 3/32 in (2.38 mm) hex key. Pull drive magnet (28) straight off motor shaft.

MICROPUMP INSTALLATION AND OVERHAUL MANUAL

4.4.2.3 Remove two screws (29) from inside of drive housing (30). Remove drive housing (30) from motor (31). Do not disassemble motor (31). Repair is limited to replacement. Note: Refurbishment of used motors may be possible. Contact Micropump or authorized service center for further information.

4.4.3 Pump Assembly See Figure 10.

4.4.3.1 Remove three screws (25) attaching end cap (24) to pump body (21). Remove end cap (24), gasket seal (23) and two dowels(22).

4.4.3.2 Using a #6-32 UNC thread tap and tap handle remove pressure regulator vent disc (4). Thread the tap into the regulator disc (4) about 1/4" and then pull straight out. Remove driven gear assembly (10), guide (5), and spring (6) from pump body (21) by turning body gear end down and shaking.

4.4.3.3 Remove three screws (16) and plate (17) from pump body (21).

4.4.3.4 Remove magnet cup (15) by lifting straight up from pump body (21). Using an exacto knife, remove O-ring (18) from groove in body (21). Do not scratch the groove walls.

4.4.3.5 Remove magnet assembly (19) by gently prying up between the pump body (21) and the inner surface of the magnet assembly (19).

4.4.3.6 Remove gear assembly (11) by sliding shaft out of the pump body.

4.4.3.7 Remove seat (14) with 5/32 in (3.97 mm) hex key. Turn the pump body (21) over and shake out ball (13) and spring (12).

4.4.3.8 Using a small hex key guided through the pressure regulator flow hole in the pump body (21), which is next to the threaded hole for the seat (14), remove pressure regulator piston (8) with o-rings (7 and 9). With light pressure push piston (8) straight out.

4.5 Evaluation of Motor and Drive Assembly Components

Do not apply excessive force to motor leads. Do not use solvent on electrical parts.

MICROPUMP INSTALLATION AND OVERHAUL MANUAL

- 4.5.1 Visually check drive magnet assembly (28) for chips, cracks, or other damage. Also check for magnetic grit accumulation. Refer to Section 4.5.4 “Repair” and Section 4.7 “Cleaning”. **Do not disassemble motor (31) for the following checks.**
- 4.5.2 Visually inspect motor (31) case for any damage that may compromise the o-ring seal which seals the two portions of the motor case.
- 4.5.3 Use an ohmmeter to check for shorts to ground between motor leads and motor case. There should be none. Resistance between leads should be at least 10-20 megaohms. Rotate motor shaft slowly and check this value. The resistance will vary, but should never go to zero.
- 4.5.4 Test motor for performance in accordance with the values listed below. Use the appropriate tools listed in section 4.2.
 - 4.5.4.1 Normal input voltage 27-29 Volts DC
 - 4.5.4.2 Maximum no load current at 28 VDC: 0.25 amps
 - 4.5.4.3 Output speed at 28 VDC, no load: 8100-8500 rpm
 - 4.5.4.4 Rotation (viewed from shaft end) CW with red (+), black (-).
- 4.5.5 User repair of the motor and drive housing assembly (3) is limited to replacing the drive magnet (28), the motor (31), or both. Refurbishment of the motor may be possible. Contact Micropump or authorized service center for further information.
 - 4.5.5.1 Replace any motor that does not pass the electrical tests given in Section 4.5 “Evaluation”
 - 4.5.5.2 If the motor shaft shows setscrew marks other than on the flat, stone or hone off burrs and verify shaft is not bent. Replace motor if shaft is bent. Mask off bearings to prevent contamination shaft when stoning or honing the shaft.
 - 4.5.5.3 Replace any motor with the following conditions: excessively noisy bearings, motor fails to operate smoothly, or motor shaft has excessive end-play (>.010” measured with dial indicator). These conditions indicate worn bearings.
 - 4.5.5.4 Replace any drive magnet (28) that is chipped, cracked, or otherwise damaged.

4.6 Evaluation of Pump Assembly Components

MICROPUMP INSTALLATION AND OVERHAUL MANUAL

Note: most of the pump assembly components are included in the factory supplied service overhaul kit. Except for required inspection of the pump body (21) and the end cap (24), the following inspections are optional. They may assist in the investigation of an early failure or to gather specific documentation regarding product life versus component wear or system conditions.

- 4.6.1 Evaluation of pump body and end cap
Inspect pressure regulator hole in body assembly (21). See figure 4. This hole is precisely machined for size, smoothness of finish, and roundness. These conditions apply to all regulator hole features, but especially to a depth of 1/4 in. (6.35 mm) where o-ring (7) of piston (8) operates. Inspect gear cavity area of pump body (21) and wear face of end cap (24). Some circular grooving of these wear surfaces is normal and not undesirable, but deep grooves or uneven wear is not. If pressure regulator hole in body assembly is damaged, or if deep grooves or uneven wear are visible, or if staining or signs of corrosion are visible on internal surfaces, do not attempt to repair.
- 4.6.2 Inspect four bushings (20) in body (21). Check that bushing bores (I.D.s) are not worn out-of-round. Check that a #30 drill blank (.1285 in dia., 3.264 mm) will pass all the way through, but not be excessively loose. The gear shafts are designed to have clearance (or play) in the bushings. However, excessively loose bushings can cause rapid gear wear. Bushings should be replaced when gears are replaced.
- 4.6.3 Visually inspect gear assemblies (10 and 11) for wear. Visually compare with a new gear. Check that the shafts are not grooved and that the gear teeth have not changed shape. If precision measuring tools are available, a measurement comparison with the new gears may be valuable. Slight grooving of the shafts is normal if the surface of the grooves look polished. This is caused by occasional pieces of grit getting into the bushing and then washing out again.
- 4.6.4 Insert gears (10 and 11) into pump body (21). Check for backlash by holding one gear stationary and rotating the other back and forth between the stationary teeth. There should be play, but only about .005". Watch for tight centers or any tendency to stick. By rotating the gears, feel for repeating tight areas in the mesh. If there is a tight spot, pull one gear out and change the mesh until they turn smoothly.
- 4.6.5 Inspect piston (8) for distortion marks or foreign matter on the bottom of the large O-ring (7) groove. Piston is to be replaced.
- 4.6.6 Inspect O-rings (7, 9 and 18) for cracks and wear. In general, all O-rings should be replaced.
- 4.6.7 Inspect gasket seal (23) for imperfections.

MICROPUMP INSTALLATION AND OVERHAUL MANUAL

- 4.6.8 On all other parts, note any excessive damage. If replacement parts are not provided in the service overhaul kit, the pump should be replaced.

4.7 Cleaning of Pump Assembly Components

- 4.7.1 Clean all metal and plastic parts in Stoddard Solvent. Do not scratch machined pressure regulator hole in pump body (21). Remove any foreign matter or residue from pump body (21), and blow dry with clean, dry compressed air. Make sure that all wear and sealing surfaces are clean and free of surface defects.
- 4.7.2 Remove any particles clinging to the driven magnet (19) or magnet (28) by pressing the sticky side of masking tape against the particles and removing the tape. Keep driven (19) or driving magnet (28) away from iron filings or other magnetic grit to avoid contamination. Clean magnet with Stoddard Solvent.

4.8 Removal/Replacement of Bushings

- 4.8.1 Remove four old bushings (20) with a #6-32 thread tap in a tap handle. Remove two bushings (20) from each side of pump body (21). Screw tap about 1/4" into bushing and then pull straight out.
- 4.8.2 Install new four bushings (20) with bushing insertion tool shown in Figure 5. This tool may be purchased from Micropump Corporation as P/N 5465, but is included with each service kit. NOTE: This tool is designed to install bushings to the proper depth - slightly below body surfaces. Also refer to Figure 11. Orient the bushings with lube notches facing the gear cavity area of the pump body (21).

4.9 Reassembly of Pump Assembly

- 4.9.1 See Figure 10. Place spring (12), then ball (13) into pump body (21). With a 5/32 in. (3.97 mm) hex key and torque wrench, screw seat (14) into body assembly and tighten to 10-12 in.lb. Shake body assembly. The ball and spacer would rattle, indicating proper freedom.
- 4.9.2 Place O-ring (18) in groove in pump body (21).
- 4.9.3 Lightly lubricate O-rings (7 and 9) with specified silicon grease (see Section 4.3.2). Install on piston (8). Put small quantity of grease on O-ring (7) and insert the piston (8) backwards (with pointed end facing out), sliding it up and down. When the pressure regulator bore is well lubricated, install the piston correctly. Do not push the piston in backwards deeper than 1/4 in. (6.35 mm). If the piston is inserted deep enough to be seen through the "out" port, the O-ring may be damaged

MICROPUMP INSTALLATION AND OVERHAUL MANUAL

by the sharp edges of the intersecting holes. Only push down lightly on the piston during assembly.

- 4.9.4 Place spring (6) and guide (5) into the hole in piston (8).
- 4.9.5 Install a new pressure regulator vent disc (4). With the pump body (21) on a flat surface, orient the vent disc (4) with small vent hole away from the pump body cavity nearest to the pressure regulator hole. See Figure 3, this vent hole must be visible and free from debris after assembly of the end cap (24). Use something larger than the vent disc press evenly into the regulator hole until flush.
- 4.9.6 Install two dowel pins (22) into dowel pin holes in pump body (21).
- 4.9.7 Using a small amount of silicone grease as mentioned in Section 4.3.2 between the thumb and forefinger, apply a light even coat of grease to gasket seal (23). Orient the seal as shown in Figure 10 and carefully place seal over dowel pins (22).
- 4.9.8 Place gear assembly (11) into center hole in pump body (21). Place gear assembly (10) into other hole in body assembly (21). Spin gear assembly (11) with slotted end of shaft extending from other end of pump body (21) to be sure the gears turn freely. If smooth rotation of both gears is not achieved, find and remove the cause of binding (burrs, misalignment, tight bushings, etc.).
- 4.9.9 Loosen lock nut (27) and back pressure regulator adjuster screw (26) out of end cap (24), so that adjuster screw is roughly sticking out an even amount on both sides. Install end cap (24) over dowel pins (22) and fasten to pump body (21) with three screws (25) and tighten in an even pattern to 10-11 in.lbs.
- 4.9.10 Slide driven magnet (19) onto shaft as shown in Figure 7, making sure to engage magnet key with slot in driving gear assembly (11) shaft (it should be a snug fit).
- 4.9.11 If the driven magnet (19) and gear assemblies (10 and 11) do not spin freely, find and remove the cause of binding (burrs, misalignment, tight, etc.).
- 4.9.12 Install magnet cup (15) over magnet assembly and down onto the -ring (18) in pump body (21). Place mounting plate (17) with the chamfer side of I.D. facing toward the pump body (21), over cup (15). Orient plate pattern as shown in Figure 10 (with one of the outer mounting holes directly above the pump body (21) port deck). Fasten plate (17) to pump body (21) with three screws (16) and tighten in an even pattern to 10-11 in.lbs.

MICROPUMP INSTALLATION AND OVERHAUL MANUAL

4.10 Reassembly of Motor and Drive Assembly

- 4.10.1 Install drive housing (30) to motor (31) with two screws (29). Orient the drive housing (30) access hole to motor (31) leads as shown in Figure 9. Tighten screws (29) evenly to 8-10 in.lb.
- 4.10.2 Thread setscrew (33) part way into drive magnet (28).
- 4.10.3 Rotate rotor shaft to align flat portion of shaft with access hole in motor housing (30).
- 4.10.4 Install drive magnet (8) on rotor shaft so that setscrew (7) aligns with flat portion of shaft. Set Drive Magnet (28) to axial dimensions shown in Figure 6, and tighten setscrew (33) with 3/32 in. (2.381 mm) hex key to 6-8 in.lb.

4.11 Reassembly of Pump Assembly to Motor and Drive Assembly

- 4.11.1 Attach pump assembly (2) to motor and drive assembly (3) using six screws (1). Orient pump to motor as shown in Figure 8. Tighten the six screws (1) to 6-8 in.lb.

5. Testing of Unit

- 5.1 Test Equipment Hydraulic
See Figure 2 for test setup.
- 5.2 Test Equipment Electrical
See Figure 2 for test setup.
 - 5.2.1 Source of 28 volt, D.C. power is required to operate the motor.
 - 5.2.2 Ohmmeter with 0 to 50 ohms minimum range will be required to test resistance of motor windings.
 - 5.2.3 Volt / Ammeter with a DC range to include 28 VDC and 1.0 amps
- 5.3 Test Procedure
Test unit per values listed in Section 1.2 “Specifications”. See Figure 2 for test setup.
 - 5.3.1 Install pump assembly in test stand / fixture.

MICROPUMP INSTALLATION AND OVERHAUL MANUAL

- 5.3.2 Loosen lock nut (27), then with the .050 in (1.27 mm) hex key, turn the pressure regulator screw (6) counter clockwise. The pressure gauge reading should go below 10 psig (.69 bar) indicating no excessive friction in the pressure regulator.
- 5.3.3 Close the discharge valve gradually until completely shut.
- 5.3.4 Turn the bypass adjustment screw clockwise (looking from the pump end) until discharge pressure stops rising. Then turn the adjustment screw one additional clockwise turn. The **maximum** allowable pressure for this condition should be **60 psig**. **Minimum** allowable pressure for this condition should be **35 psig**.
- 5.3.5 Tighten lock nut (27).
- 5.3.6 Apply letter “S” with a permanent marker at the end of serial number on pumphead.

6. Illustrated Parts Breakdown

This breakdown lists, describes, and illustrates all procurable parts for the Model* 09-31-316 Coffee/Lavatory pump manufactured by MICROPUMP INC., Vancouver, Washington.

6.1 Numerical Index

- 6.1.1 The Numerical Index (page 15) is compiled in accordance with the Numerical Part Filing System. Part number numerical arrangement starts on the left hand column and continues from left to right one column at a time, until part number numerical arrangement is determined.

6.2 Detailed Parts List

- 6.2.1 Detailed Parts List (page 16) consists of the complete Coffee/Lavatory pump divided into main parts and assemblies. Each assembly is followed by its component parts indented thereunder, to show their relationship to the assembly. The index numbers are numerically arranged and are used mainly to assist in locating a part once it has been found in the Numerical Index..
- 6.2.2 The complete Coffee / Lavatory pump is broken down into main parts assemblies in Figure 8. Detail breakdown for the pump assembly is Figure 10. And breakdown for motor and drive assembly is Figure 9.

6.3 How To Use Catalog

MICROPUMP INSTALLATION AND OVERHAUL MANUAL

- 6.3.1 To use catalog when the number of the part is known and it is necessary to find the illustration or description of a part, refer to Numerical Index. Find the number in Parts Number column. The corresponding number in Figure-Item column is the figure and item number of the illustration and listing of the part number in the Detailed Parts List.
- 6.3.2 When the part number is not known and it is necessary to find the part number of a component, refer to the applicable illustration of the assembly in which the part is used. Locate the part on the illustration, find its index number and then refer to the Detailed Parts List to determine the part number.

MICROPUMP INSTALLATION AND OVERHAUL MANUAL

7. Numerical Index

Part Number	Nomenclature	Figure	Index Number	Quantity
795	Screw	10	16	3
808	O-ring, Buna-N	10	18	1
820	O-ring, Buna-N	10	7	1
821	O-ring, Buna-N	10	9	1
823	Spring	10	6	1
825	Seat, Drain Valve	10	14	1
827	Ball	10	13	1
869	Guide	10	5	1
966	Piston, Pressure	10	8	1
1927	Nut	10	27	1
2301	Plate, Mounting	10	17	1
3279	Cup, Magnet	10	15	1
4572	Dowel Pin	10	22	2
6101	Bushing	10	20	4
7134	Motor, Mod 31	9	31	1
7170	Spring	10	12	1
7721	Body, Pump	10	21	1
7172	Gasket, Seal	1	23	1
7731	End Cap	10	24	1
7174	Screw	8, 10	1, 25	9
7175	Set Screw, Regulator	10	26	1
7176	Vent Disc	10	4	1
7308	Housing, Drive (Etched)	8, 9	3, 30	1
7311	Screw	9	29	2
8946	Magnet Assembly	10	19	1
80602	Hub Assembly	9	28	1
83391	Gear Assembly, Driving	10	11	1
83392	Gear Assembly, Driven	10	10	1

MICROPUMP INSTALLATION AND OVERHAUL MANUAL

8. Detailed Parts List

Part Number	Nomenclature	Figure	Index Number	Quantity
83394	Mod 09-00-316	8	2	3
795	Screw	10	16	3
808	O-ring, Buna-N	10	18	1
820	O-ring, Buna-N	10	7	1
821	O-ring, Buna-N	10	9	1
823	Spring	10	6	1
825	Seat, Drain Valve	10	14	1
827	Ball	10	13	1
869	Guide	10	5	1
966	Piston, Pressure	10	8	1
1927	Nut	10	27	1
2301	Plate, Mounting	10	17	1
3279	Cup, Magnet	10	15	1
4572	Dowel Pin	10	22	2
6101	Bushing	10	20	4
7170	Spring	10	12	1
7721	Body, Pump	10	21	1
7172	Gasket, Seal	10	23	1
7731	End Cap	10	24	1
7174	Screw	10	25	3
7175	Set Screw, Regulator	10	26	1
7176	Vent Disc	10	4	1
8946	Magnet Assembly	10	19	1
83391	Gear Assembly, Driving	10	11	1
83392	Gear Assembly, Driven	10	10	1
83393	Mod 000-31-000	8	3	1
7134	Motor, Mod 31	9	31	1
7308	Housing, Drive (Etched)	6, 9	30, 30	1
7311	Screw	9	29	2
80602	Hub Assembly	9	28	1
7174	Screw	8	1	6

MICROPUMP INSTALLATION AND OVERHAUL MANUAL

9. Troubleshooting Chart

TROUBLE	POSSIBLE CAUSE	CORRECTION
External leakage	Loose screws in cap, inlet or hoses.	Tighten as required
Pump not delivering flow or pressure (motor running)	Magnetic coupling disengaged	Shut off motor for 30 seconds - restart
	Intake line or suction filter clogged or disconnected	Clean out or connect properly
	Air leak in suction line (will also prevent priming and cause noise)	Check and eliminate as required
	Pressure regulator (bypass) not closed	Turn adjustment screw clockwise to stop - DO NOT OVERTIGHTEN
	Motor brushes or bearings worn or damaged	Replace motor
Pump not delivering flow or pressure (motor not running)	No power to motor	Check power source and connections
	Motor not turning	Replace motor
Magnetic coupling disengages before pressure reaches 35 psig	Dirt in bushings, gears, or internal magnet rub	Disassemble pump (Figures 8& 10) and check

MICROPUMP INSTALLATION AND OVERHAUL MANUAL

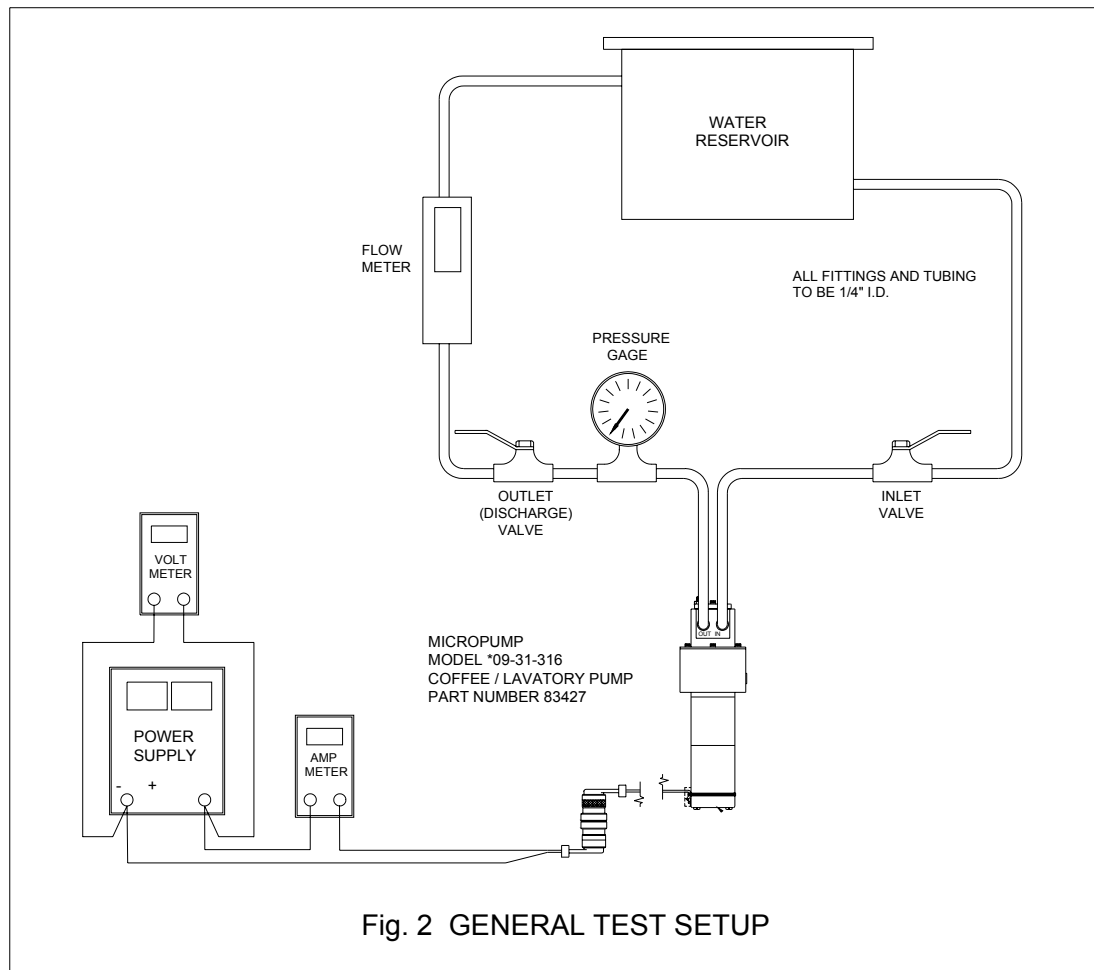
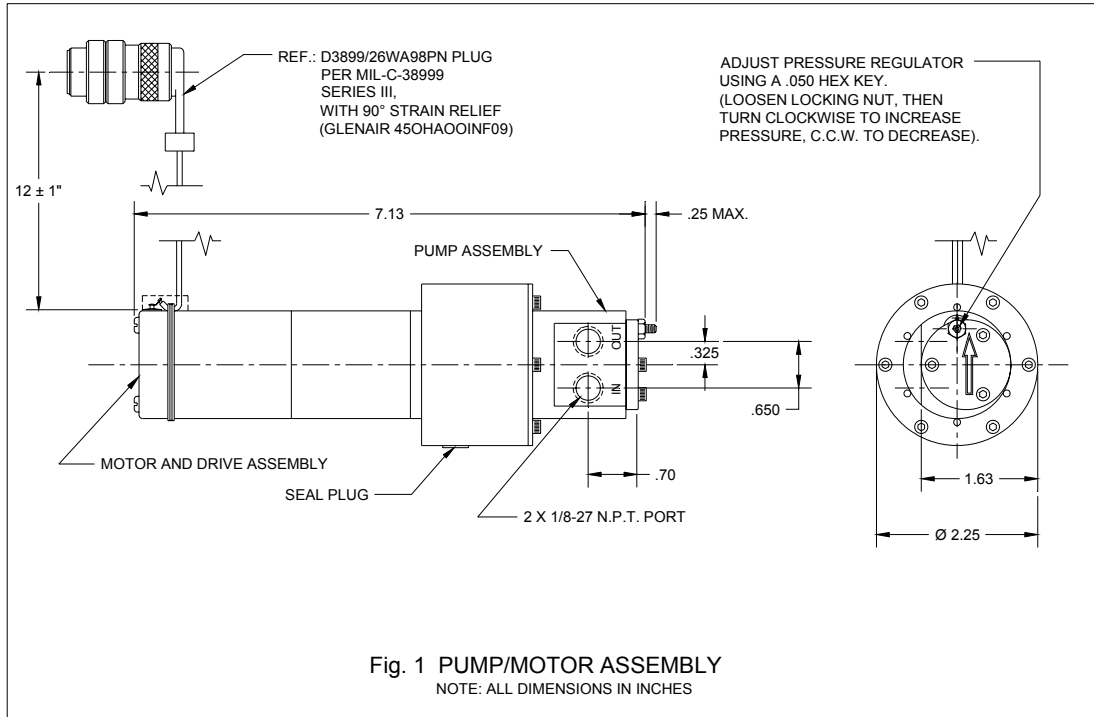

MICROPUMP INSTALLATION AND OVERHAUL MANUAL

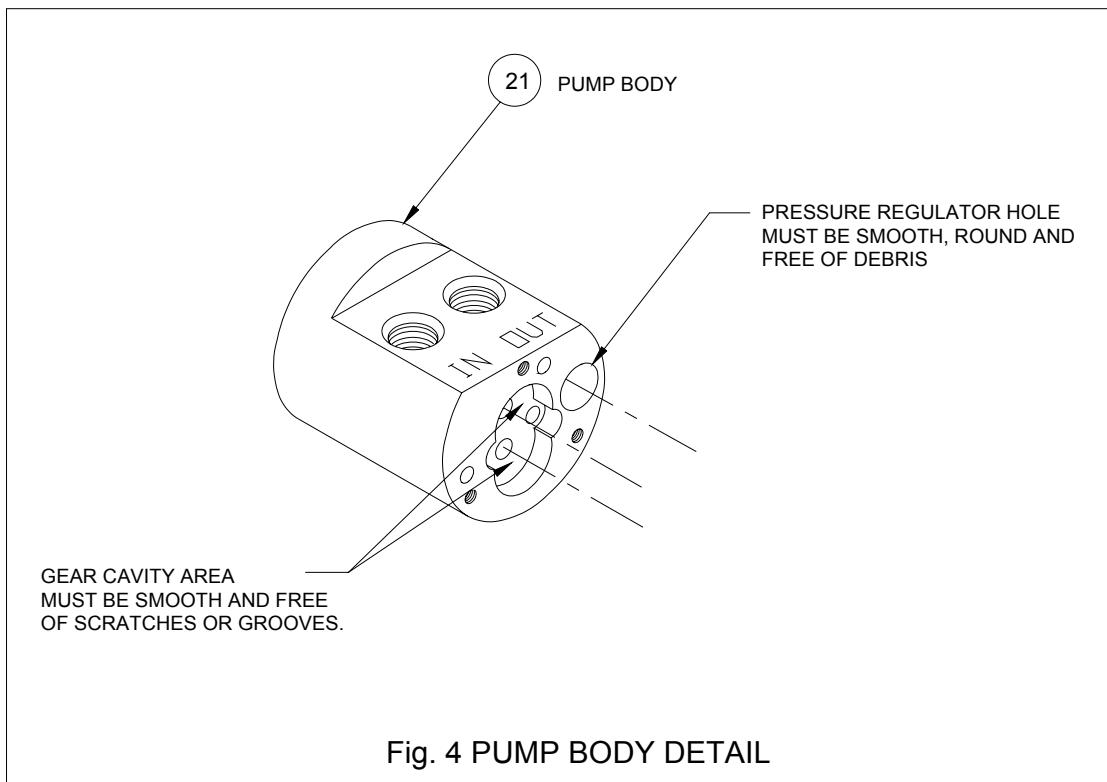
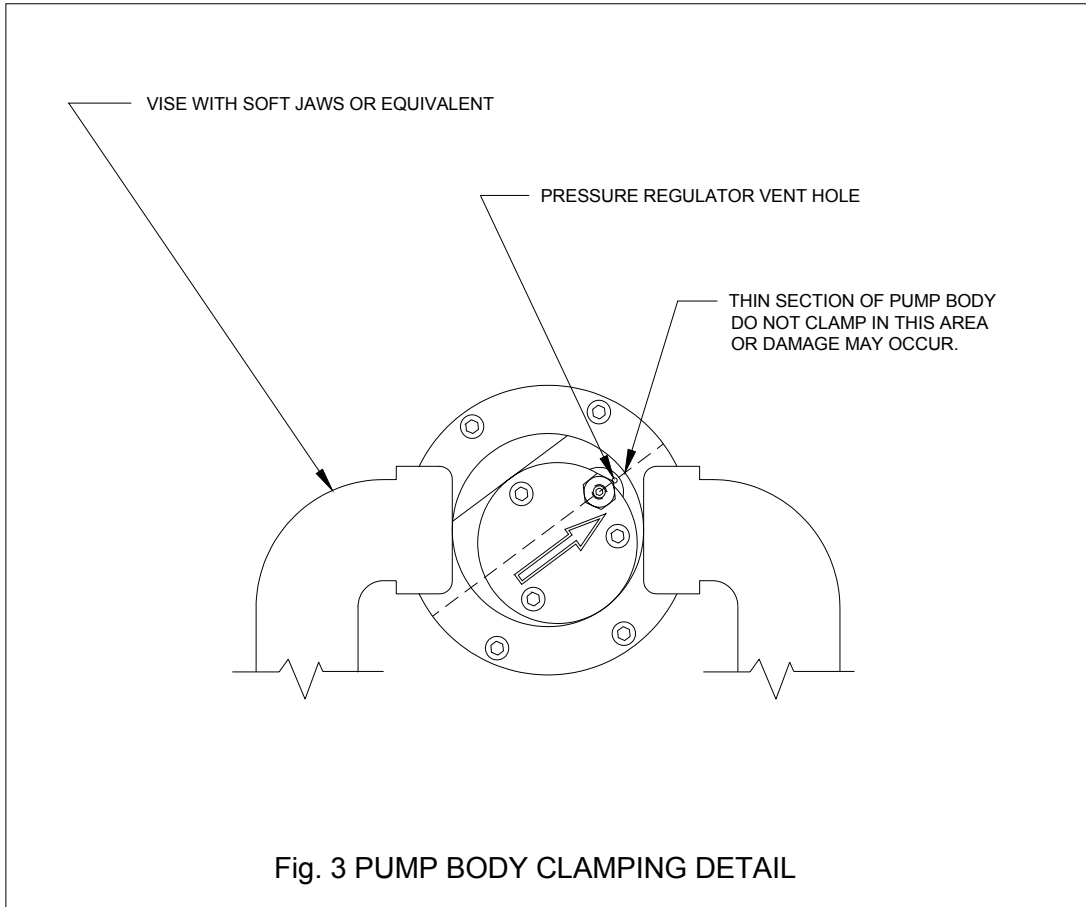

MICROPUMP INSTALLATION AND OVERHAUL MANUAL

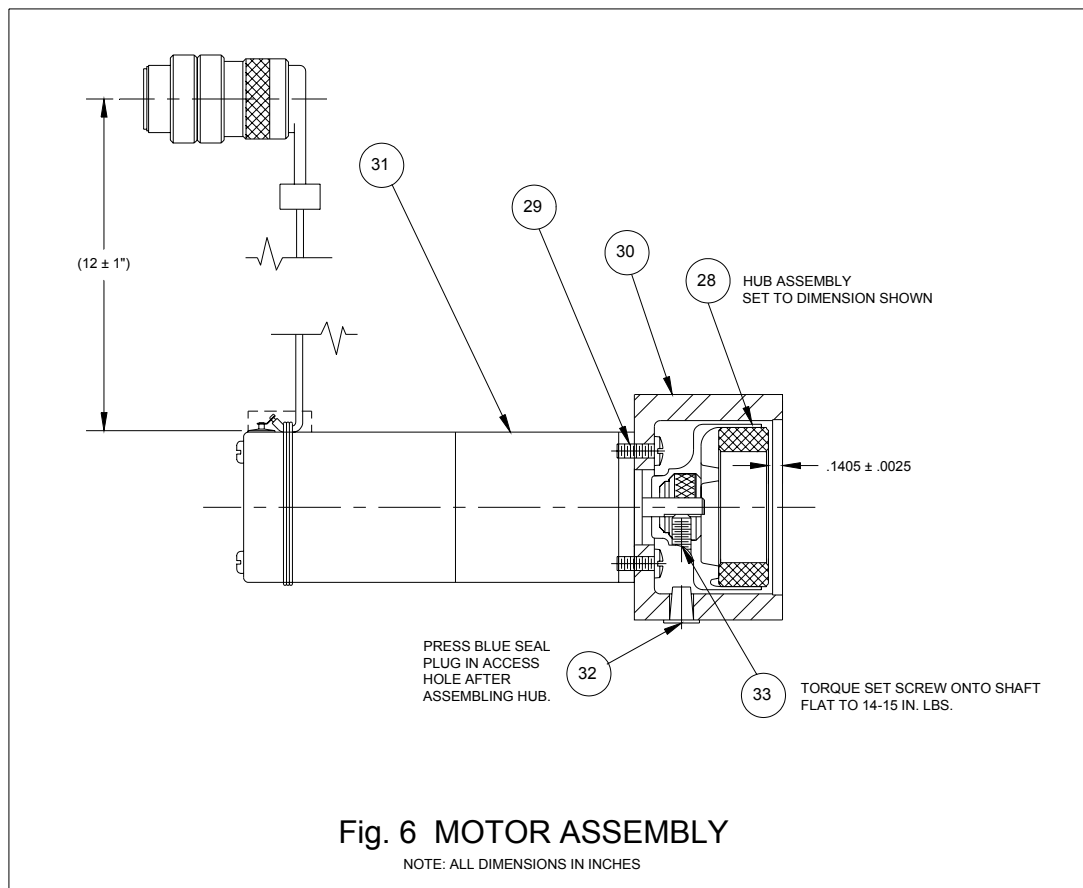
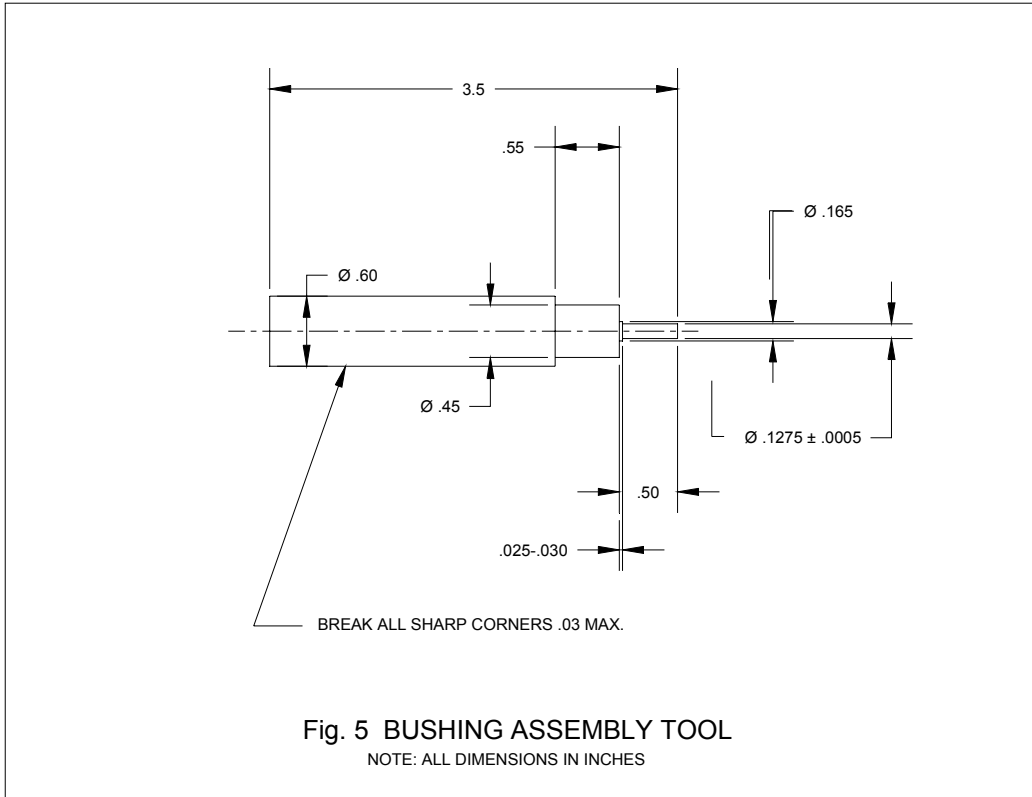

MICROPUMP INSTALLATION AND OVERHAUL MANUAL

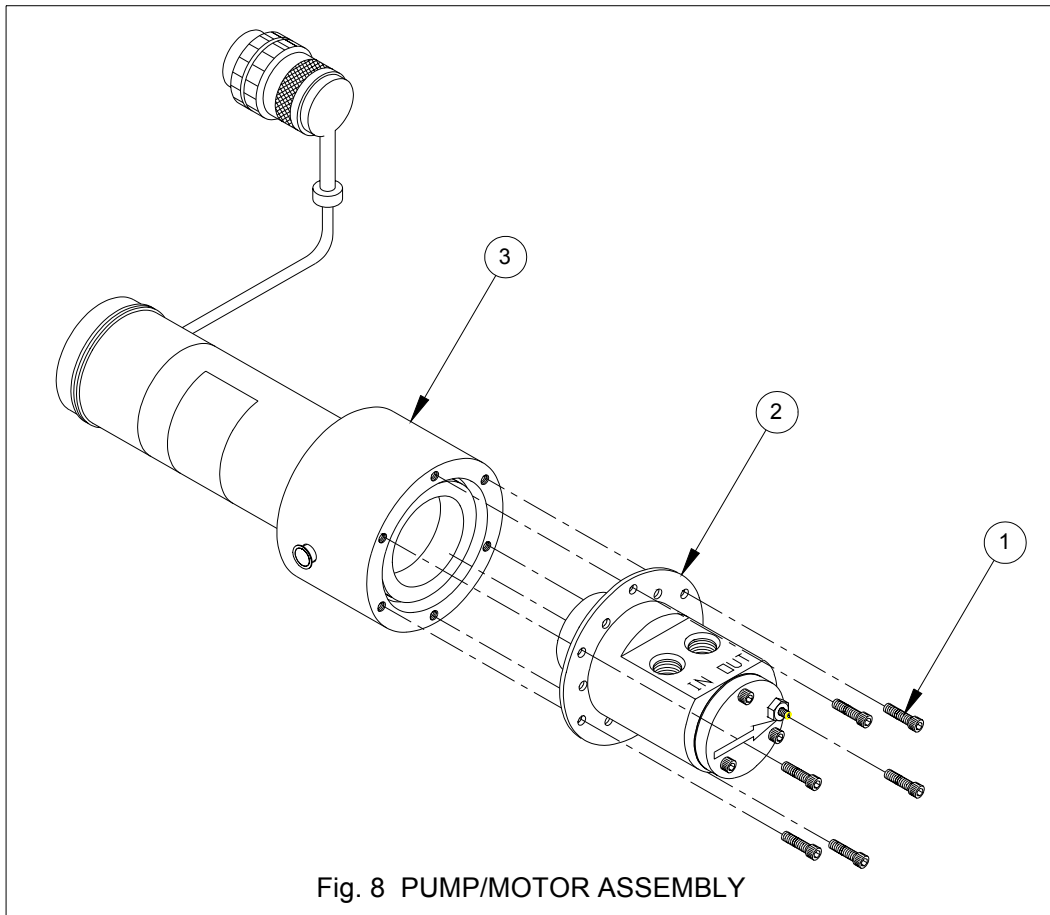
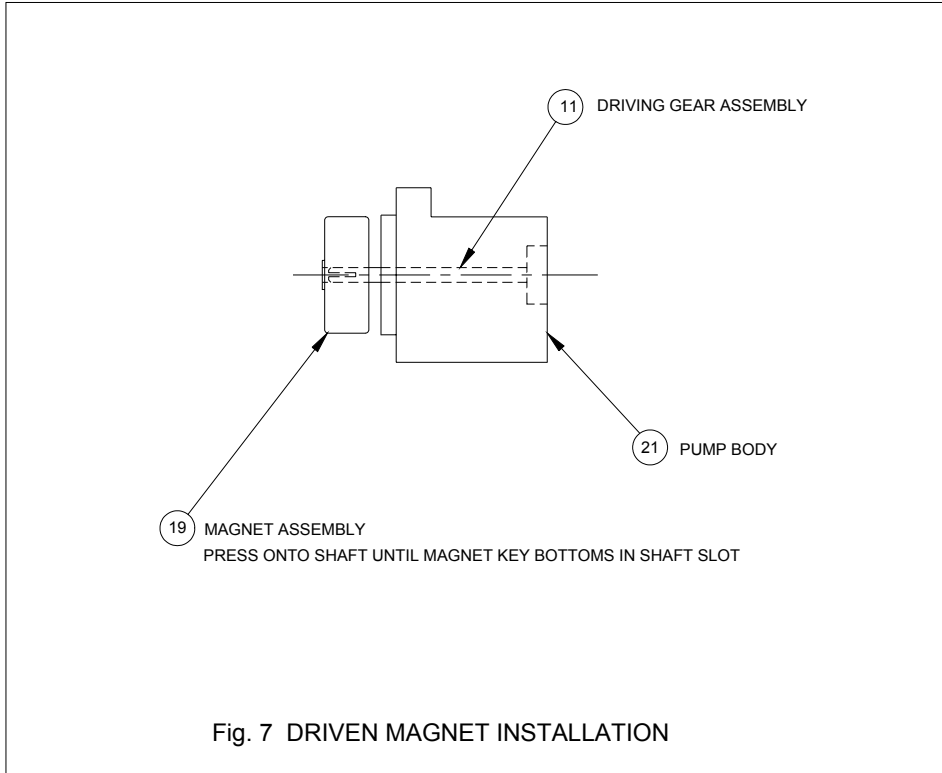

MICROPUMP INSTALLATION AND OVERHAUL MANUAL

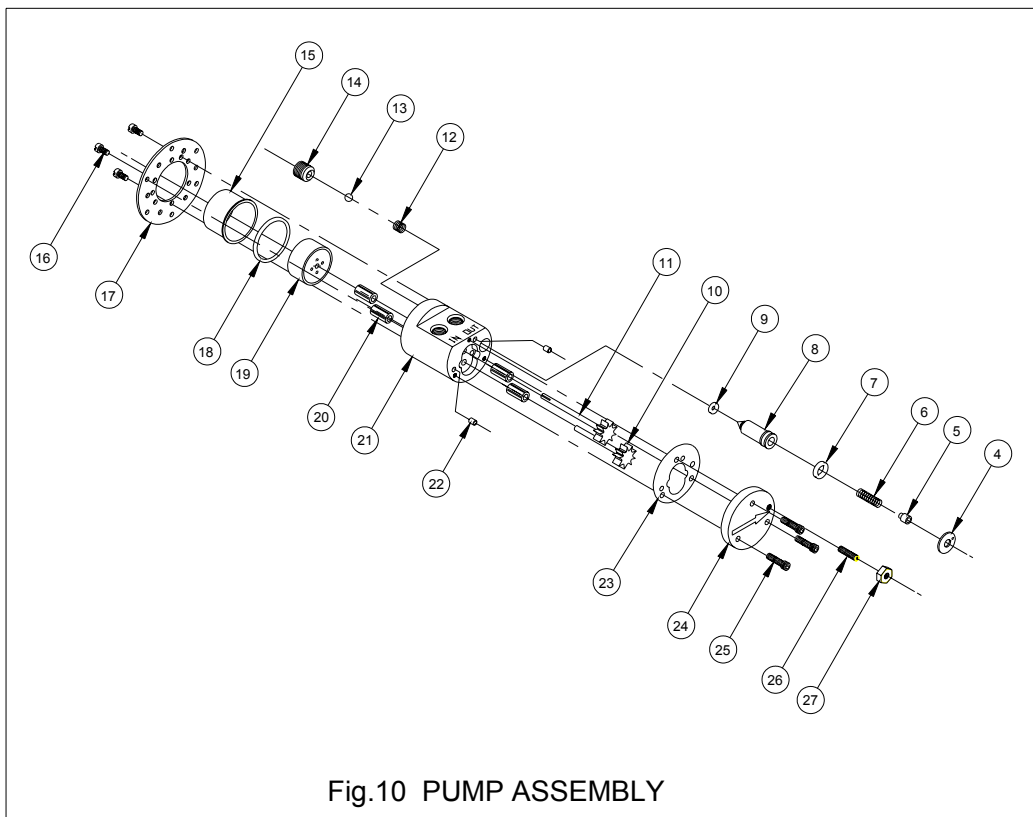
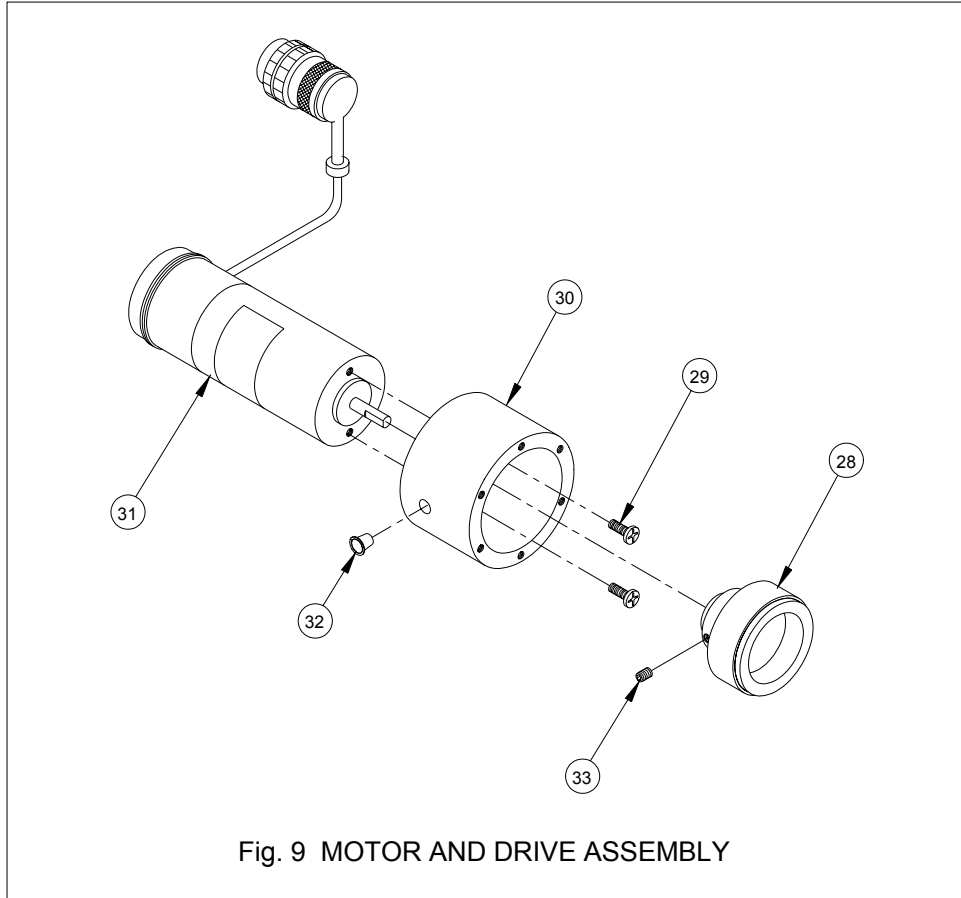

MICROPUMP INSTALLATION AND OVERHAUL MANUAL

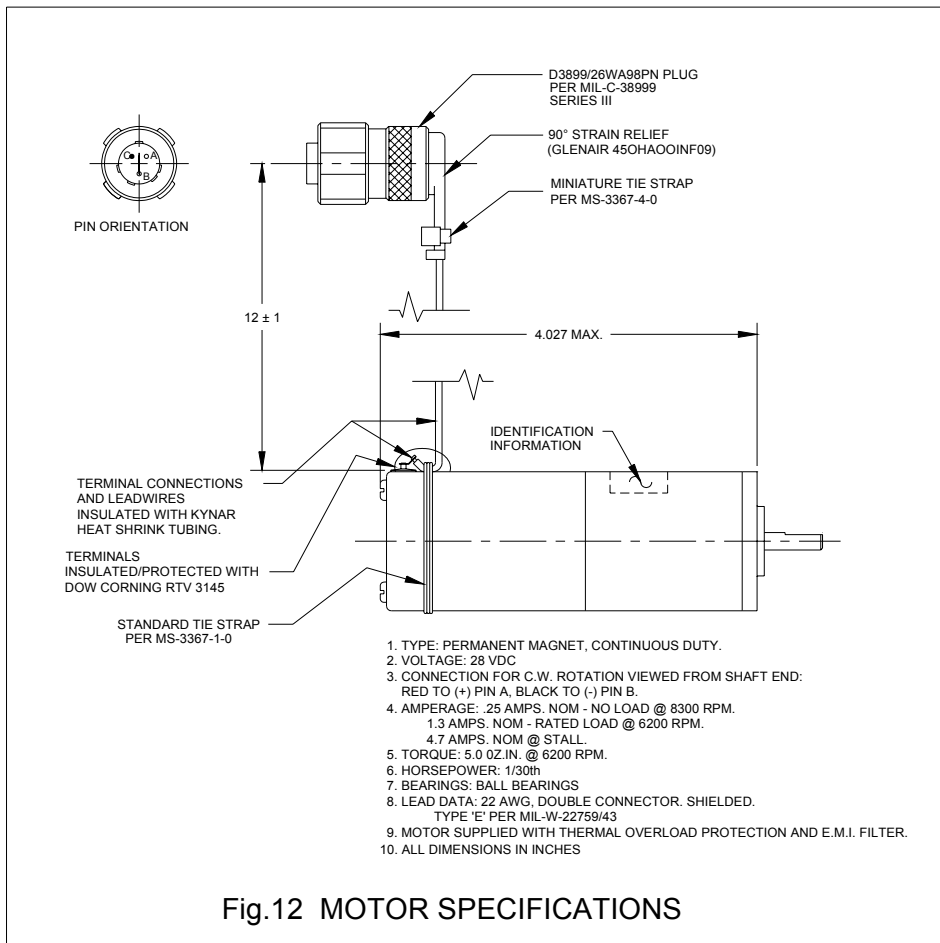
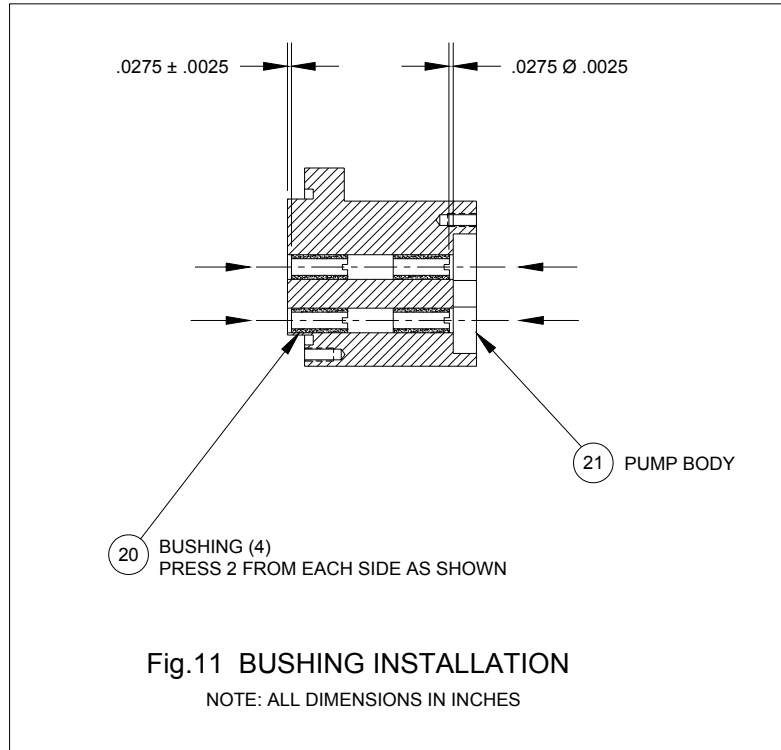

MICROPUMP INSTALLATION AND OVERHAUL MANUAL



STANDARD LIMITED WARRANTY

The products manufactured by Micropump, Inc. are warranted to be free from defects in workmanship and material at the time of shipment from the place of manufacture. Micropump will repair or replace, at its option, any part of our product that fails to conform to this warranty for a period of one year from date of manufacture, plus six months' warehouse and transit period, or for a period of one year from the date of purchase by the first user of the product, whichever expires first. In no event shall this period exceed 18 months from the date of original invoice. Micropump's obligation under this warranty is limited to the repairs or replacement of defective equipment returned to us on an F.O.B. destination basis, providing that our examination discloses that such part or parts were defective at the time of sale.

The warranty described above is the exclusive Micropump warranty and is in lieu of all other warranties, express or implied, including any warranty of merchantability or fitness for a particular purpose or any warranty previously issued. We neither assume nor authorize any person to assume for us any other liability in connection with the sale or use of our equipment.

No warranty of any kind is made or shall be imposed with respect to any pump or parts (1) which have not been properly installed and tested in operation, (2) which have been subject to misuse, negligence, acts of God or the elements, or any other form of casualty, or (3) which have been repaired or altered outside of Micropump's plant in a way, so as, in our judgment, to affect performance or reliability.

The parties agree that the buyer's sole and exclusive remedy against Micropump shall be for repair or replacement of defective parts under the conditions stated above. The buyer agrees that no other remedy (including but not limited to incidental or consequential damages for lost profits, lost sales, loss of use, injury to person or property, or any other incidental or consequential loss) shall be available to it.

This warranty shall not apply to prototype pumps, experimental pumps, special pumps, or brush-type electric motors. A copy of the warranty on the aforementioned equipment is available on request.

The adjustment or replacement of defective parts made under this warranty will not extend the original warranty period.

