



Model No. 668D3

COFFEPUMP

Part No. 9168

Product Code: O/C GJAN21.DB6B-DC310B

**OVERHAUL MANUAL
with
ILLUSTRATED PARTS LIST**

P/N 5914
Rev D

MICROPUMP, INC.

A Unit of IDEX Corporation

PO Box 8975, Vancouver, WA 98668-8975 • Phone: 360/253-2008 • Fax: 360/253-8294

MICROPUMP LIMITED

A Subsidiary of Micropump, Inc.

Howard Road, Eaton Socon, St. Neots, Cambs., PE 19 8ET England, • Phone: (011) (44)1480-356600 Fax: (011) (44) 1480-356300

1.0 Introduction

1.1 Description

1.1.1 The Model 668D3 Coffeepump supplies water to the coffeemaker. It can be installed in the galley water system or in the coffeemaker itself. It is a gear-type water pump with a built in by-pass, magnetically coupled to a self-contained motor assembly. All seals are static and seal positively against leaks. The pump assembly can be drained for freeze protection. The by-pass incorporates a pressure regulator, which maintains the pump output pressure at a set level above cabin ambient pressure, regardless of the inlet pressure to the pump. (The only exception is, if the pump inlet pressure exceeds the pressure regulator setting, the output pressure then equals the inlet pressure.) Therefore, it can be used interchangeably in aircraft with or without pressurized water tanks. The pump is not self-priming.

1.2 Table of Leading Particulars

Length 5.75 in. (146 mm)
 Width 2.50 in. (63.5 mm)
 Height 2.38 in. (60.5 mm)
 Weight 1.45 lbs. (.66 kg)
 Ports 1/8-27 NPT
 Motor 28 Volt DC
 Pressure Regulator Adjustment 10-35 psig (.69-2.42 bar)
 Flow 0-0.5 gpm (0-1.9 liter/min)

1.3 General Installation Instructions

1.3.1 The pump should be oriented to facilitate priming with a minimum of restriction on the inlet side of the pump. A positive head should be provided such as from an overhead tank. A vent line plumbed immediately on the discharge of the pump will facilitate priming. The pump should not be installed in an ambient temperature over 180 degrees F (82 degrees C) nor should the pump continuously see water at temperatures higher than this. Provision should be made to shut the pump off when no flow is being used to prevent overheating and undue wear on the component parts. The pump should be drained if it is to be in freezing ambient temperatures.

CAUTION: When installing or removing fittings in the pump's ports, **do not** apply heavy wrench torque by holding the motor, as this will misalign the magnetic coupling. **Do not** thread the "out" fitting more than seven (7) total turns into the "out" port of the pump body. Any more than seven (7) full turns will jam the fitting against the pressure regulator piston (15) and cause the regulator to malfunction. If teflon tape is used for thread sealant be careful that no teflon scraps get into the pump head.

2.0 Overhaul Instructions

2.1 General

2.1.1 Figure numbers in the Numerical Parts List (Paragraph 4.2) refer to exploded views of the major assemblies shown in the Detailed Parts List, (Paragraph 4.3) of the Manual.

2.1.2 Tools required for overhaul are as follows:

MICROPUMP, INC.

A Unit of IDEX Corporation

PO Box 8975, Vancouver, WA 98668-8975 • Phone: 360/253-2008 • Fax: 360/253-8294

MICROPUMP LIMITED

A Subsidiary of Micropump, Inc.

Howard Road, Eaton Socon, St. Neots, Cambs., PE 19 8ET England, • Phone: (011) (44)1480-356600 Fax: (011) (44) 1480-356300

2.1.2.1 .050 in (1.27 mm), 3/32 in. (2.38 mm), 5/32 in. (3.97 mm) Hex Keys.
2.1.2.2 3/16 in. (4.76 mm)-wide flat blade screwdriver.

2.1.2.3 Bushing tool (MICROPUMP P/N 5465)

2.1.2.4 #30 Reamer (.1285 in., 3.264 mm)

2.1.2.5 1/4 in. Drill press (6.35 mm)

2.1.2.6 Soft jaw vice.

2.1.3 Cleaning fluids and lubricants required are as follows:

2.1.3.1 Stoddard Solvent is the only cleaning fluid required.

2.1.3.2 Use any one of the following silicone lubricants for assembly of the pressure regulator:

2.1.3.2.1 Dow Corning Hight Vacuum Grease Silicone lubricant

2.1.3.2.2 Dow Corning 55M grease

2.1.3.2.3 Dow Corning 4 grease

2.1.3.2.4 Dow Corning 11 compound

CAUTION: **Use no substitutes.** The "slip-stick" characteristics of lubricants vary greatly. The use of an unlisted lubricant can cause the pressure regulator to malfunction.

2.1.4 Electrical requirements are as follows:

2.1.4.1 Source of 28 volt, direct current power is required to operate the motor.

2.1.4.2 Test Equipment:

2.1.4.2.1 Ohmmeter with 0 to 50 ohms minimum range will be required to test resistance of motor windings.

2.1.4.2.2 Voltmeter with a DC range to include 28 VDC.

2.1.4.2.3 Ammeter with a DC range to include 1.0 amps.

2.1.5 The following test stand, Figure 3, or equivalent, will be required to check the operation of reassembled units.

MICROPUMP, INC.

A Unit of IDEX Corporation

PO Box 8975, Vancouver, WA 98668-8975 • Phone: 360/253-2008 • Fax: 360/253-8294

MICROPUMP LIMITED

A Subsidiary of Micropump, Inc.

Howard Road, Eaton Socon, St. Neots, Cambs., PE 19 8ET England, • Phone: (011) (44)1480-356600 Fax: (011) (44) 1480-356300

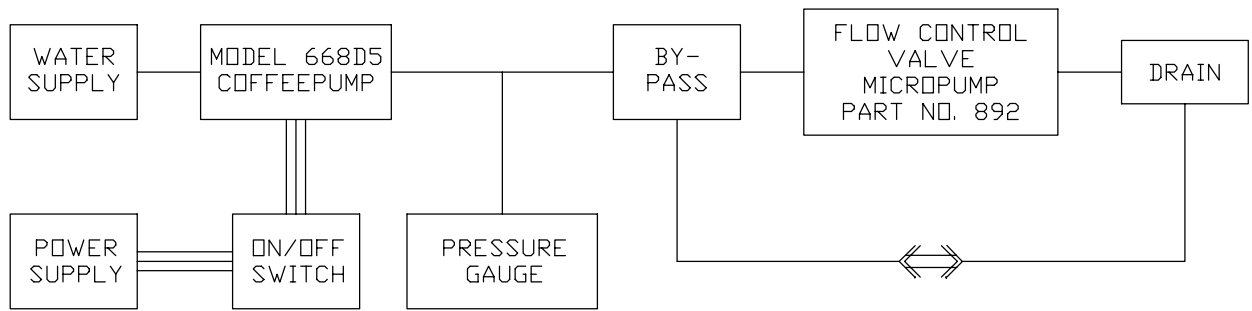

Figure 3

2.1.6 Do all work on a clean surface.

2.2 Disassembly of Pump Assembly (1) from Motor and Drive Housing Assembly (4) (See Figure 1)

CAUTION: If it is necessary to clamp the pump body in a vise to install or remove "in" and "out" fittings, clamp it at an angle to avoid crushing the thin section at the pressure regulator hole. The pressure regulator hole is precisely honed to size and roundness. Any distortion will cause regulator to malfunction or leak. A damaged pressure regulator hole cannot be repaired and the body must be replaced.

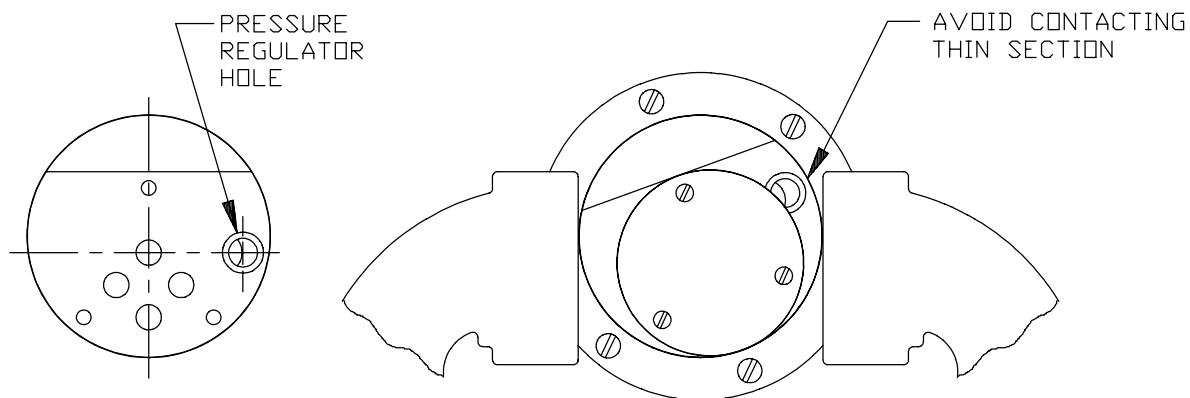

Figure 4

2.2.1 Remove screws (2) attaching pump assembly (1) and bracket (3) to motor and drive housing assembly (4).

2.2.2 Remove pump assembly (1) and bracket (3).

2.3 Disassembly of Motor and Drive Housing Assembly.

NOTE: Do not damage or shorten external wiring if motor is to be re-used.

2.3.1 Rotate drive magnet (8) to align setscrew (7) with access hole in drive housing.

MICROPUMP, INC.

A Unit of IDEX Corporation

PO Box 8975, Vancouver, WA 98668-8975 • Phone: 360/253-2008 • Fax: 360/253-8294

MICROPUMP LIMITED

A Subsidiary of Micropump, Inc.

Howard Road, Eaton Socon, St. Neots, Cambs., PE 19 8ET England, • Phone: (011) (44)1480-356600 Fax: (011) (44) 1480-356300

2.3.2 Loosen setscrew (7) with 3/32 in (2.38 mm) hex key. Pull drive magnet (8) straight off rotor shaft.

2.3.3 Remove screws (10) and washers (9) from inside of drive housing (6). Separate drive housing assembly (6) from motor (5).

2.3.4 Do not disassemble motor (5). Repair is limited to replacement.

2.4 Disassembly of Pump Assembly (See Figure 2)

2.4.1 Remove screws (23) attaching cap (22) to body assembly (1). Remove cap (22) and adjuster-seal assembly (21).

2.4.2 Remove gear assembly (14), guide (19), and spring (18) from body assembly (1) by turning body gear end down and shaking.

2.4.3 Remove screws (12) and plate (10) from body assembly.

2.4.4 Remove cup (9) by lifting straight up from body assembly (1). Remove O-ring (4) from groove in body assembly (1).

2.4.5 Remove magnet assembly (8) by prying up between the body assembly (1) and the inner hub of the magnet assembly (8).

CAUTION: **Do not** pull on the magnet assembly to remove as this could cause the assembly to come apart.

2.4.6 Remove gear assembly (13) by sliding shaft out of the body.

2.4.7 Remove seat (7) with 5/32 in (3.97 mm) hex key. Turn the body assembly (1) over and shake ball (6) and spacer (5) out.

2.5 Cleaning

2.5.1 Clean all metal and plastic parts in Stoddard Solvent. Blow dry with clean, dry compressed air.

CAUTION: **Do not** scratch honed pressure regulator hole in body assembly (1).

2.5.2 Remove any foreign matter or residue from body assembly (1), and blow dry with clean, dry compressed air.

2.5.3 Magnet Assembly and Drive Magnet.

2.5.3.1 Remove any particles clinging to the magnet by pressing the sticky side of the masking tape against the particles and removing the tap.

2.6 Inspection of Motor and Drive Housing Assembly (4)(See Figure 1)

2.6.1 Drive Magnet Assembly Condition.

MICROPUMP, INC.

A Unit of IDEX Corporation

PO Box 8975, Vancouver, WA 98668-8975 • Phone: 360/253-2008 • Fax: 360/253-8294

MICROPUMP LIMITED

A Subsidiary of Micropump, Inc.

Howard Road, Eaton Socon, St. Neots, Cambs., PE 19 8ET England, • Phone: (011) (44)1480-356600 Fax: (011) (44) 1480-356300

- 2.6.1.1 Visually check drive magnet assembly for chips, cracks, or other damage. Also check for magnetic grit accumulation. Refer to repair or replacement (section 2.8) and cleaning (section 2.5)

Note: Do not disassemble motor for the following checks:

CAUTION: **Do not** use solvent on electrical parts.

- 2.6.2 Use an ohmmeter to check for shorts to ground between motor leads and motor case. There should be none. Resistance between leads should be 10 to 40 Ohms. Rotate motor shaft slowly and check this value. The resistance will vary between these values but should never go to zero or open circuit.

- 2.6.3 Test motor for performance in accordance with the values listed below:

- 2.6.3.1 Normal voltage 26-28 Volts DC

- 2.6.3.2 Maximum current 27 Volts DC at No Load 0.20 AMPS

- 2.6.3.3 Output speed 27 Volts DC at No Load 7100-8500 RPM

- 2.6.3.4 Rotation (viewed from shaft end) CW with red (-) and black (+).

2.7 Inspection of Pump Assembly (see Figure 2)

- 2.7.1 Inspect bushings (3) in body (2). Check that bushing bores are not worn out-of-round. Check that a #30 drill blank (.1285 in dia., 3.264 mm) will pass all the way through, but not be excessively loose.

Note: The gear shafts normally fit very loosely in the bushings. However, excessively loose bushings can cause gear wear and bushings should be replaced when gears are replaced.

- 2.7.2 Visually inspect gear assemblies (13 and 14) for wear. Visually compare with a new gear, and check that the shafts are not deeply grooved and that the gear teeth have not changed shape. Slight grooving of the shafts is normal if the surface of the grooves look polished. This is caused by occasional pieces of grit getting into the bearing and then washing out again.

- 2.7.3 Insert gears (13 and 14) into body assembly (1). Check for backlash and smooth meshing. Watch for tight centers or any tendency to stick.

- 2.7.4 Inspect pressure regulator hole in body assembly (1). This hole is precisely honed for size, smoothness of finish, and roundness. These conditions apply to a depth of 1/4 in. (6.35 mm) where O-ring (17) of piston (15) operates. (Refer to figure 5.)

- 2.7.5 Inspect piston (15) for marks or foreign matter on the bottom of the large O-ring (17) groove.

MICROPUMP, INC.

A Unit of IDEX Corporation

PO Box 8975, Vancouver, WA 98668-8975 • Phone: 360/253-2008 • Fax: 360/253-8294

MICROPUMP LIMITED

A Subsidiary of Micropump, Inc.

Howard Road, Eaton Socon, St. Neots, Cambs., PE 19 8ET England, • Phone: (011) (44)1480-356600 Fax: (011) (44) 1480-356300

PUMP BODY

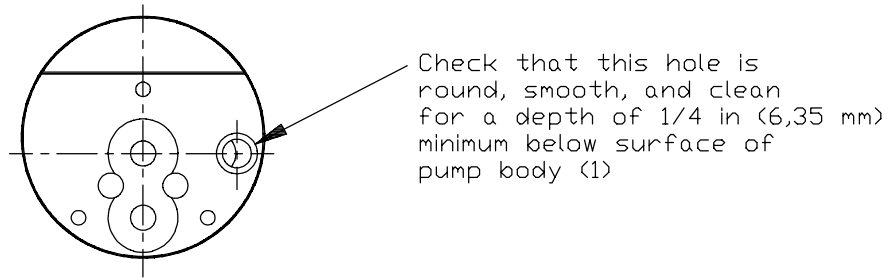

Figure 5

2.7.6 Inspect O-ring (17) for cracks and wear.

2.7.7 Inspect adjuster-seal assembly (21) for wear or imperfection. Some circular grooving of the wear surface is normal and not undesirable.

2.7.8 Visually inspect all other parts for wear or damage that may affect serviceability.

Note: Keep magnet assembly (8) away from iron filings or other magnetic grit to avoid contamination.

2.8 Repair or Replacement

2.8.1 Motor and Drive Housing Assembly Parts (see Figure 1).

2.8.1.1 Repair of the motor and drive housing assembly is limited to replacing the drive magnet, the motor, or both.

2.8.1.1.1 Replace any motor that does not pass the electrical tests given in Inspection (section 2.6).

2.8.1.1.2 If the motor shaft shows setscrew marks other than on the flat, hone off burrs and check for a bent shaft. Replace motor if shaft is bent.

CAUTION: Mask off bearings to prevent contamination when honing shaft.

2.8.1.1.3 Replace any motor with excessively noisy bearings or if motor fails to operate smoothly.

2.8.1.1.4 Replace any drive magnet that is chipped, cracked, or otherwise damaged.

2.8.2 Pump Assembly Parts (See Figure 2)

2.8.2.1 If pressure regulator hole in body assembly is damaged, do not attempt to repair. Replace body assembly. Damaged bodies may be returned to manufacturer for evaluation and repair if possible.

2.8.2.2 Remove and replace bushings (3) in body (2), as follows:

2.8.2.2.1 Remove old bushings with a 6-32 tap in a tap handle. Screw tap about 1/4" into bushing and then pull straight out.

2.8.2.2.2 Install new bushings with bushing insertion tool shown in Figure 6. This tool may be fabricated by user or purchased from Micropump Corp. as P/N 5465. **NOTE:**

MICROPUMP, INC.

A Unit of IDEX Corporation

PO Box 8975, Vancouver, WA 98668-8975 • Phone: 360/253-2008 • Fax: 360/253-8294

MICROPUMP LIMITED

A Subsidiary of Micropump, Inc.

Howard Road, Eaton Socon, St. Neots, Cambs., PE 19 8ET England, • Phone: (011) (44)1480-356600 Fax: (011) (44) 1480-356300

This tool is designed to install bushings to the proper depth - slightly below body surfaces.

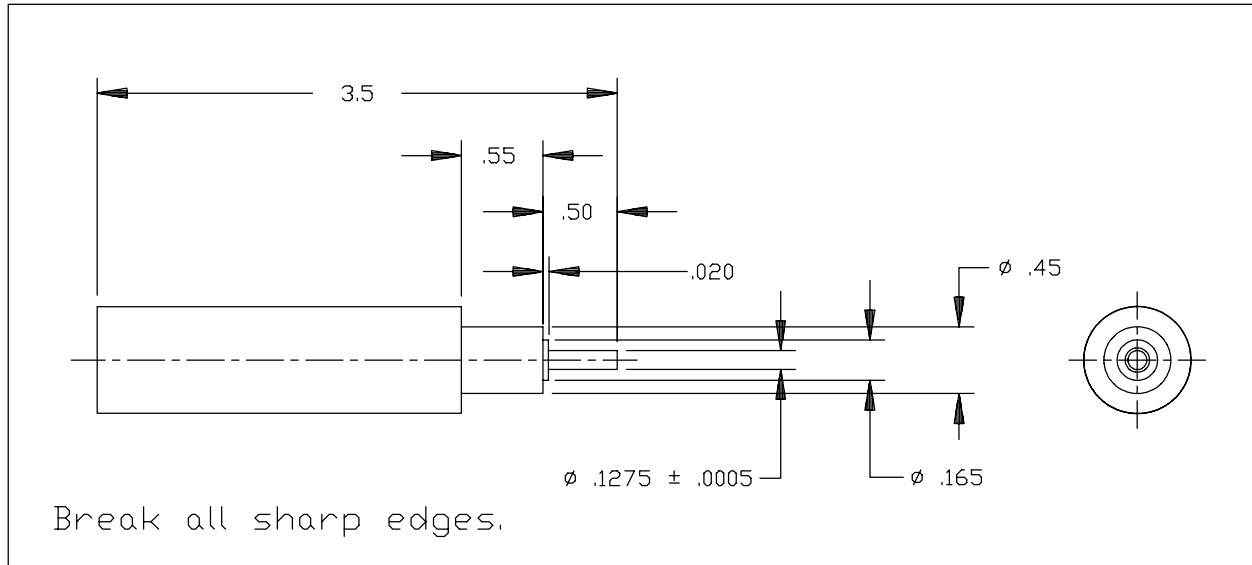

Figure 6

2.8.3 Making sure that the body assembly (1) is setting square on drill press table, ream bushings with a #30 (.1285 in., 3.64 mm) reamer. Spindle speed should be approximately 1100 RPM.

2.8.3.1 Repair of gear assemblies (13 and 14) is limited to replacement of those which do not pass inspection.

CAUTION: Certain older pumps were built with seven (7) tooth gear assemblies; these gear assemblies are not interchangeable with the current nine (9) tooth assemblies, and the assemblies must be replaced in pairs.

2.8.3.2 Repair of piston (15) is limited to replacement.

2.8.3.3 On all other parts, if damage is extensive or if minor repair will affect serviceability, replace the part.

2.8.3.4 In general, all O-rings should be replaced.

2.9 Assembly of Motor and Drive Housing Assembly (4) (See Figure 1).

2.9.1 Install housing assembly (6) to motor (5) with screws (10) and washers (9).

2.9.2 Thread setscrew (7) part way into drive magnet (8).

2.9.3 Rotate rotor shaft to align flat portion of shaft with access hole in motor housing (6).

MICROPUMP, INC.

A Unit of IDEX Corporation

PO Box 8975, Vancouver, WA 98668-8975 • Phone: 360/253-2008 • Fax: 360/253-8294

MICROPUMP LIMITED

A Subsidiary of Micropump, Inc.

Howard Road, Eaton Socon, St. Neots, Cambs., PE 19 8ET England, • Phone: (011) (44)1480-356600 Fax: (011) (44) 1480-356300

2.9.4 Install drive magnet (8) on rotor shaft so that setscrew (7) aligns with flat portion of shaft. Set Drive Magnet (8) to axial dimensions shown in Figure 7, and tighten setscrew (7) with 3/32 in. (2.381 mm) hex key.

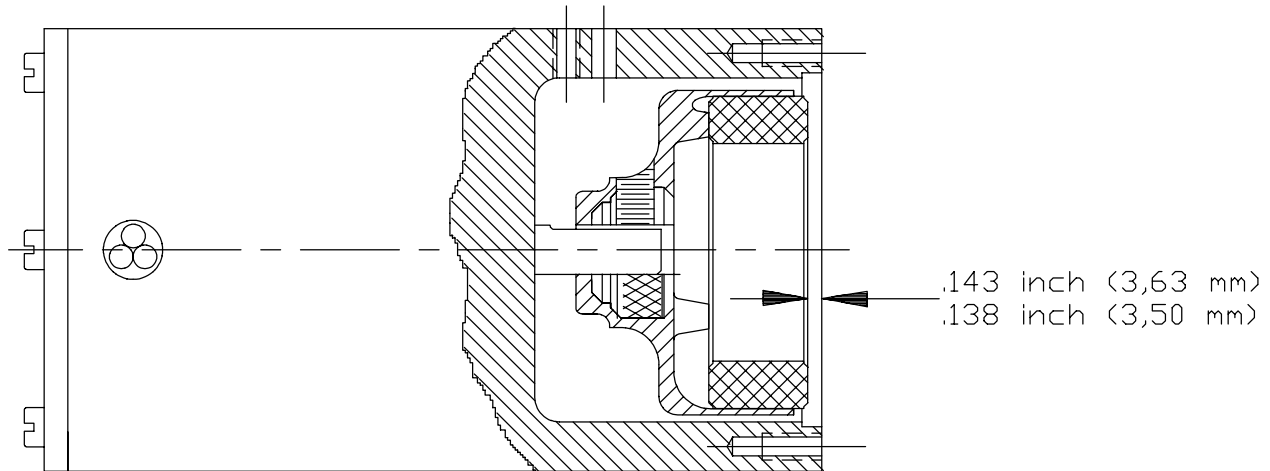

Figure 7

2.10 Assembly of Pump Assembly (5)(see Figure 2)

2.10.1 Place spacer (5), then ball (6) into body assembly (1). With a 5/32 in. (3.97 mm) hex key, screw seat (7) into body assembly and tighten. Shake body assembly. The ball and spacer should rattle, indicating proper freedom.

2.10.2 Place O-ring (4) in groove in body assembly (1).

2.10.3 Lightly lubricate O-rings (16 and 17) with specified silicon grease (see paragraph 2.1.3.2). Install on piston (15). Put small quantity of grease on O-ring (17) and inset the piston (15) backwards, sliding it up and down. When the pressure regulator bore is lubricated, install the piston correctly.

CAUTION: Do not push the piston in backwards deeper than 1/4 in. (6.35 mm). If the piston is inserted deep enough to be seen through the "out" port, the O-ring may be damaged by the sharp edges of the intersecting holes.

2.10.4 Place spring (18) and guide (19) into the hole in piston (15).

2.10.5 Place adjuster-seal assembly (21) on body assembly (1) making sure that the pilot on the adjuster-seal assembly goes into the pressure regulator hole. The hex socket of the screw in the adjuster-seal assembly (21) must face out.

2.10.6 Place gear assembly (13) into center hole in body assembly (1). Place gear assembly (14) into other hole in body assembly (1). Spin gear assembly (13) to be sure the gears turn freely.

MICROPUMP, INC.

A Unit of IDEX Corporation

PO Box 8975, Vancouver, WA 98668-8975 • Phone: 360/253-2008 • Fax: 360/253-8294

MICROPUMP LIMITED

A Subsidiary of Micropump, Inc.

Howard Road, Eaton Socon, St. Neots, Cambs., PE 19 8ET England, • Phone: (011) (44)1480-356600 Fax: (011) (44) 1480-356300

2.10.7 Install cap (22), screws (23) and tighten.

2.10.8 Driven magnet adjustment.

2.10.8.1 Slide driven magnet (8) onto slot on driving gear (13).

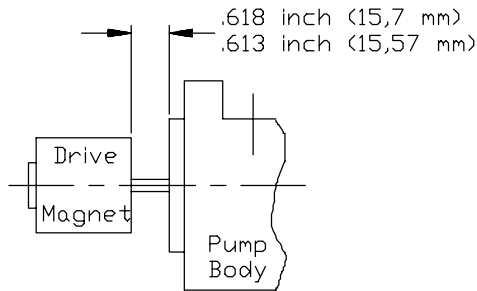

Figure 8

2.10.8.2 Set driven magnet (8) to height shown in Figure 8.

2.10.8.3 If the magnet and gear assembly does not spin freely, find and remove the cause of binding (burrs, misalignment, tight bushings, etc.)

2.10.9 Install cup (9) on body assembly (1). Place plate (10) with the chamfer side toward the body assembly (1), over cup (9). Install screws (12) and tighten.

2.11 Assembly of Pump Assembly (1) to Motor and Drive Housing Assembly (4)(see Figure 1).

2.11.1 Attach pump assembly (1) and bracket (3) to motor and drive housing (4).

2.11.2 Install screws (2) and tighten.

3.0 Test Procedure and Trouble Shooting

3.1 Test Procedure

3.1.1 In order to test the pump unit, use a test stand in accordance with the Schematic Diagram (Figure 3), and proceed as follows:

3.1.1.1 To quickly purge the lines of air, turn the directional control valve to by-pass the Flow Control Valve. Turn the motor on.

3.1.1.2 When the lines are free of air, turn the directional control valve so flow goes through Flow Control Valve.

3.1.1.3 Insert the .050 in (1.27 mm) hex key in the hole in the cap (22) at the pressure regulator piston (15) location. Turn the adjustment key counter clockwise. The pressure gauge reading should go below 10 psig (.69 bar) indicating no excessive friction in the pressure regulator.

MICROPUMP, INC.

A Unit of IDEX Corporation

PO Box 8975, Vancouver, WA 98668-8975 • Phone: 360/253-2008 • Fax: 360/253-8294

MICROPUMP LIMITED

A Subsidiary of Micropump, Inc.

Howard Road, Eaton Socon, St. Neots, Cambs., PE 19 8ET England, • Phone: (011) (44)1480-356600 Fax: (011) (44) 1480-356300

3.1.1.4 Turn the adjustment key clockwise. The pressure gauge reading should reach 35 psig (2.38 bar) before the magnetic drive decouples. This indicates no excessive friction in the pump.

3.1.1.5 Adjust pump to desired operating pressure.

3.1.1.6 Test complete.

3.2 Trouble Shooting.

TROUBLE	POSSIBLE CAUSE	CORRECTION
Pressure won't go to 10 psig (.68 bar)	Stuck pressure regulator piston.	Replace O-ring (17) and clean pressure regulator hole with solvent. Regrease according to Paragraph 2.10.3.
Magnetic coupling disengages before pressure reaches 35 psig (2.38 bar).	Dirt in bushings, gears, or internal magnet rub.	Disassemble pump (Figure 1 and 2) and check
External leakage.	Loose screws in cap, inlet, or hoses.	Tighten
Pump not delivering flow or pressure (motor running).	Magnet coupling disengaged.	Shut off motor for 30 seconds - restart.
	Intake line or suction filter clogged or disconnected.	Clean out or connect properly.
	Air leak in suction line (will also prevent priming and cause noise).	Eliminate
	Improper adjustment on pressure regulator valve.	Adjust to required pressure.

4.0 Illustrated Parts Breakdown

4.1. Introduction

4.1.1 Purpose

4.1.1.1 This breakdown lists, describes, and illustrates all procurable parts for the Model 668D3 Coffeepump manufactured by MICROPUMP INC., Vancouver, Washington.

4.1.2 Numerical Index

4.1.2.1 The Numerical Index is compiled in accordance with the Numerical Part Filing System. Part number numerical arrangement starts on the left hand column and continues from left to right one column at a time, until part number numerical arrangement is determined.

4.1.3 Detailed Parts List

MICROPUMP, INC.

A Unit of IDEX Corporation

PO Box 8975, Vancouver, WA 98668-8975 • Phone: 360/253-2008 • Fax: 360/253-8294

MICROPUMP LIMITED

A Subsidiary of Micropump, Inc.

Howard Road, Eaton Socon, St. Neots, Cambs., PE 19 8ET England, • Phone: (011) (44)1480-356600 Fax: (011) (44) 1480-356300

4.1.3.1 Detailed Parts List consists of the complete Coffeepump divided into main parts and assemblies. Each assembly is followed by its component parts indented thereunder, to show their relationship to the assembly. The index numbers are numerically arranged and are used mainly to assist in locating a part once it has been found in the Numerical Index.

4.1.3.2 The complete Coffeepump is broken down into main parts and assemblies in Figure 2. Detail breakdown for the pump assembly is in Figure 1.

4.1.4 How To Use Catalog

4.1.4.1 To use catalog when the number of the part is known and it is necessary to find the illustration or description of a part, refer to Numerical Index. Find the number in Parts Number column. The corresponding number in Figure-Item column is the figure and item number of the illustration and listing of the part number in the Detailed Parts List.

4.1.4.2 When the part number is not known and it is necessary to find the part number of a component, refer to the applicable illustration of the assembly in which the part is used. Locate the part on the illustration, find its index number and then refer to the Detailed Parts List to determine the part number.

4.2 Numerical Parts List

Part No.	Figure	Index	Quantity Required
784	1	2	1
795	1	12	3
799	1	23	3
808	1	4	1
820	1	16	1
821	1	17	1
822	1	5	1
823	1	18	1
825	1	7	1
827	1	6	1
869	1	19	1
876	1	13	1
877	1	14	1
916	1	1	1
926	2	6	1
943	2	3	1
961	1	22	1
966	1	15	1
967	2	1	1
1153	2	9	2
2301	1	10	1
2547	1	24	2
3279	1	9	1
3565	2	7	1

MICROPUMP, INC.

A Unit of IDEX Corporation

PO Box 8975, Vancouver, WA 98668-8975 • Phone: 360/253-2008 • Fax: 360/253-8294

MICROPUMP LIMITED

A Subsidiary of Micropump, Inc.

Howard Road, Eaton Socon, St. Neots, Cambs., PE 19 8ET England, • Phone: (011) (44)1480-356600 Fax: (011) (44) 1480-356300

4469	2	2	7
4502	2	5	1
Continued on next page.			
Part No.	Figure	Index	Quantity Required
4566	2	10	2
5065	1	3	4
5461	1	6	7
8656	1	21	1
8946	1	8	1
80121	2	4	1
80602	2	8	1

4.3 Detailed Parts List

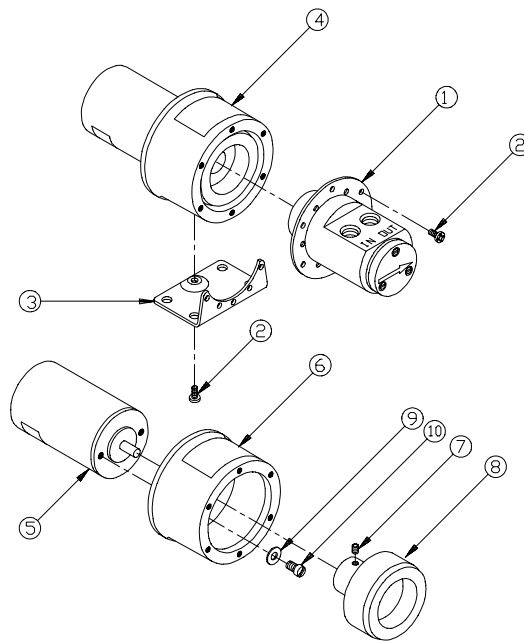

668D3 COFFEE PUMP
Figure 1

Figure Item	Part No.	Nomenclature	Units per Assembly
1	9168	Coffeepump Assembly (mod 668D3)	1
1	967	Pump Assembly	1
2	4469	Screw	7
3	943	Bracket	1
4	80121	Motor and Drive Housing Assy	1
5	4502	Motor - 28 VDC	1
6	926	Housing Assy - Drive	1
7	814	Set Screw	1

MICROPUMP, INC.

A Unit of IDEX Corporation

PO Box 8975, Vancouver, WA 98668-8975 • Phone: 360/253-2008 • Fax: 360/253-8294

MICROPUMP LIMITED

A Subsidiary of Micropump, Inc.

Howard Road, Eaton Socon, St. Neots, Cambs., PE 19 8ET England, • Phone: (011) (44)1480-356600 Fax: (011) (44) 1480-356300

8	80602	Magnet Assembly - Driving	1
9	1153	Washer	2
10	4566	Screw - Motor Mounting	2

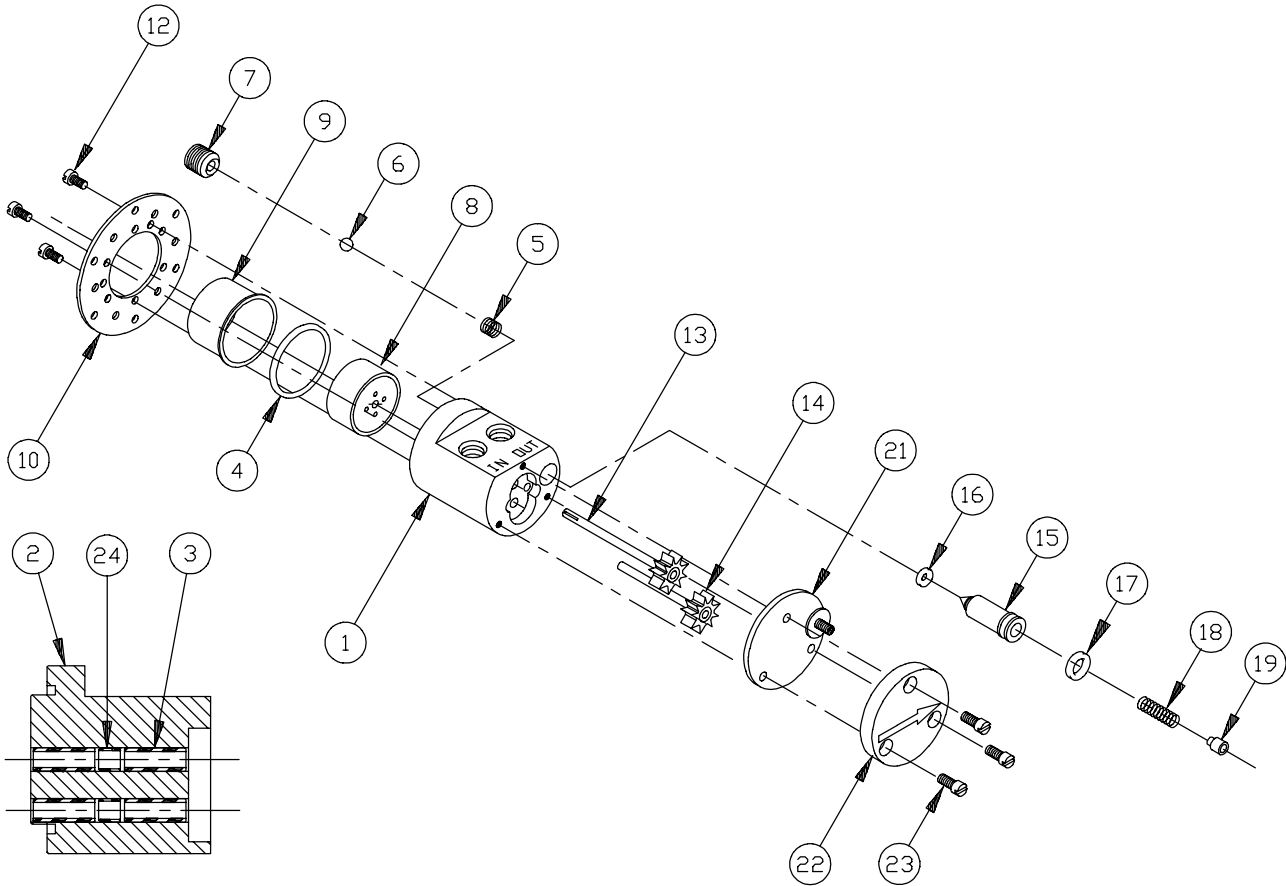

668D3 Pump Assembly

Figure Item	Part No.	Nomenclature	Units per Assembly
2	967	Pump Assembly	1
1	916	Body Assembly	1
2	784	Body	1
3	5065	Bushing	4
4	808	O-Ring - Magnet Cup Seal	1
5	822	Spacer - Coiled Wire	1
6	827	Ball	1

MICROPUMP, INC.

A Unit of IDEX Corporation

PO Box 8975, Vancouver, WA 98668-8975 • Phone: 360/253-2008 • Fax: 360/253-8294

MICROPUMP LIMITED

A Subsidiary of Micropump, Inc.

Howard Road, Eaton Socon, St. Neots, Cambs., PE 19 8ET England, • Phone: (011) (44)1480-356600 Fax: (011) (44) 1480-356300

7	825	Seat - Drain Valve	1
8	8946	Magnet Assembly - Driven	1
9	3279	Cup - Magnet	1
Continued next page.			
Figure Item	Part No.	Nomenclature	Units per Assembly
10	2301	Plate - Pump Mounting	1
12	795	Screw	3
13	876	Gear Assembly - Pump Driving	1
14	877	Gear Assembly - Pump Driven	1
15	966	Piston-Press. Reg. By-Pass	1
16	820	O-Ring-Press. Reg. By-Pass Seat	1
17	821	O-Ring-Press. Reg. By-Pass Piston	1
18	823	Spring-Press. Reg. By-Pass	1
19	869	Guide - Reg. Spring Adjustment	1
21	8656	Adj. - Seal Assy. - Press. Reg. By-Pass	1
22	961	Cap. - Micropump	1
23	799	Screw - Pump Cap Mounting	1
24	2547	Spacer	2

MICROPUMP, INC.

A Unit of IDEX Corporation

PO Box 8975, Vancouver, WA 98668-8975 • Phone: 360/253-2008 • Fax: 360/253-8294

MICROPUMP LIMITED

A Subsidiary of Micropump, Inc.

Howard Road, Eaton Socon, St. Neots, Cambs., PE 19 8ET England, • Phone: (011) (44)1480-356600 Fax: (011) (44) 1480-356300