

Operating manual for micro annular gear pumps
mzr-2521 and mzr-2921

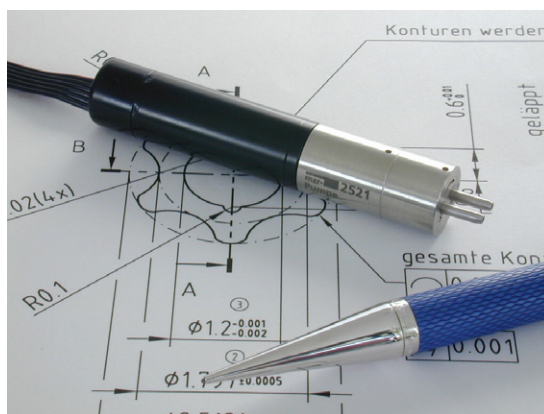

HNP Mikrosysteme GmbH
Juri-Gagarin-Ring 4
D-19370 Parchim
Phone: 03871/451-301
Fax: 03871/451-333
E-mail: info@hnp-mikrosysteme.de
<http://www.hnp-mikrosysteme.de>

Last update: June 2008

Contents

1	General information	1
1.1	Application scope of the pumps	1
1.2	Product information	1
1.3	Measurements	2
1.4	Flow charts	3
1.5	Technical data of the micro annular gear pump mZR-2521 and mZR-2921	4
1.6	Technical data of the drive	5
2	Safety instructions	7
2.1	Safety symbols in this operating manual	7
2.2	Staff qualification and training	7
2.3	Safety-conscious work	7
2.4	Safety instructions for the operator	8
2.5	Safety instructions for maintenance, check and assembly of the pump	8
2.6	Unauthorized pump conversions and spare part manufacture	8
2.7	Improper modes of operation	9
2.8	General safety instructions	9
3	Transport and intermediate storage	10
3.1	Shipment of the pumps and protection measures	10
3.2	Transport	10
3.3	Intermediate storage	10
4	Description of the micro annular gear pump	11
4.1	Operating principle of the micro annular gear pump	11
4.2	Construction	13
4.3	Construction materials	13
4.4	Liquid supply	14
5	Optional modules	16
5.1	Gear box module (optional)	17
5.2	By-pass module (optional)	18
5.3	Drive without encoder (optional)	20
5.4	Drive with a high resolution encoder (optional)	21
5.5	Stepper motor drive (optional)	22
5.6	Brushless DC motor as drive (option)	23
6	System integration	24
6.1	Checkup before the first assembly	24
6.2	Mounting of the micro annular gear pump	24
6.3	General instructions for the assembly of the liquid supply network	25
6.4	Filter selection and use	26

6.5	Operation with the S-ND control unit	27
6.6	Operation with the S-KD control unit (optional)	31
6.7	Operation with the S-KG control unit (optional)	34
6.8	Operation with the S-BL control unit (optional)	38
7	The startup/shutdown of a pump	41
7.1	Preparing for operation	41
7.2	Startup of the micro annular gear pump	41
7.3	Flushing procedure after use	41
7.4	Shutdown of the micro annular gear pump	44
7.4.1	Conservation	46
7.4.2	Dismantling of the system	47
7.5	Problem shooting	48
7.6	Return of the micro annular gear pump to the manufacturer	48
8	Software »mzz-pump control«	49
9	»Motion Manager« software (optional)	52
9.1	Direct drive control	52
9.2	Programming of the control unit	54
9.3	Transfer of a mcl-file to the drive	54
10	Accessories for microfluidic systems	61
11	Non-liability clause	61
12	Electromagnetic compatibility (EMC)	61
13	Problem shooting	62
14	Service, maintenance and warranty	65
15	Contact person	66
16	Legal information	67
17	Safety information for the return of already employed micro annular gear pumps and components	68
17.1	General information	68
17.2	Declaration of media in contact with the micro annular gear pump	68
17.3	Shipment	68
18	Declaration of media in contact with the micro annular gear pump and its components	69
19	Appendix	70

1 General information

This operation manual contains basic instructions to be followed during integration, operation and maintenance of the m zr[®] micro annular gear pump. For this reason it is necessary to read it carefully before any handling of the device. The present manual should always be kept at the operation site of the micro annular gear pump.

In case assistance is needed, please indicate the pump type visible on the housing.

1.1 Application scope of the pumps

The micro annular gear pumps m zr-2521 and m zr-2921 described in this manual are suitable for continuous delivery and discrete dosage of water, watery solutions, solvents, methanol, oils, lubricating liquids, paints and varnishes as well as many other liquids.



If you intend to handle any aggressive, poisonous or radioactive liquids, you must conform to safety measures as according to the regulations in force. Any project concerning handling of corrosive liquids should be previously discussed with the pump manufacturer.



The micro annular gear pumps should not be used for "invasive" medical applications, in which the liquid having had contact with the pump is re-introduced to the body.



The micro annular gear pumps must not be used in aircrafts and spacecrafts or other vehicles without prior consent of the manufacturer.



The data concerning resistance of the pumps to manipulated liquids is elaborated according to the best of HNP Mikrosysteme's knowledge. However, operating parameters varying from one application case to another, no warranty for this information can be given.



The information given in this manual does not release the customer from personal obligation to check the integrity, correct choice and suitability of the pump for the intended use. The use of the micro annular gear pumps should be conform with technical norms and regulations in force.

If you wish to receive more information than comprised in this manual please contact directly HNP Mikrosysteme.

1.2 Product information

The present operating manual is valid for the micro annular gear pump types m zr-2521 and m zr-2921 manufactured by HNP Mikrosysteme GmbH, Juri-Gagarin-Ring 4, 19370 Parchim, Germany.

The date of release of the present manual figures on the cover.

1.3 Measurements

The micro annular gear pumps mzs-2521 and mzs-2921 have the same outer measurements.

The pumps are available in two versions featuring different liquid connectors. figure 1 shows the version with $\varnothing 2$ mm slip fittings on which flexible tubes with internal diameter < 2 mm are stuck. figure 2 shows the version with a manifold assembly, which is screwed and fixed with a holding nut to a preadapted support.

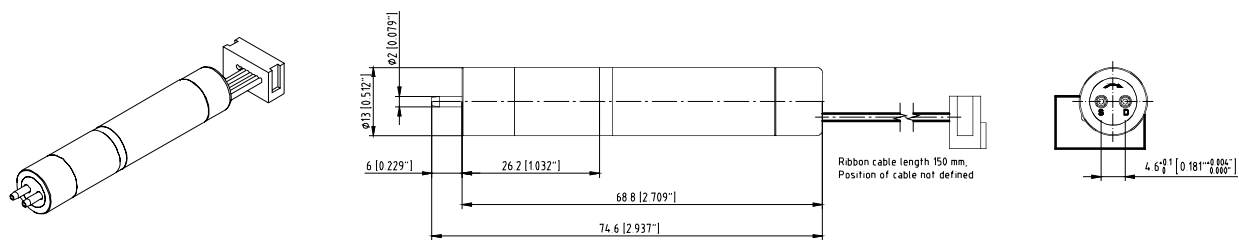

figure 1 Measurements of the micro annular gear pumps mzs-2521 and mzs-2921, version with fluid connections, slip fitting $\varnothing 2$ mm

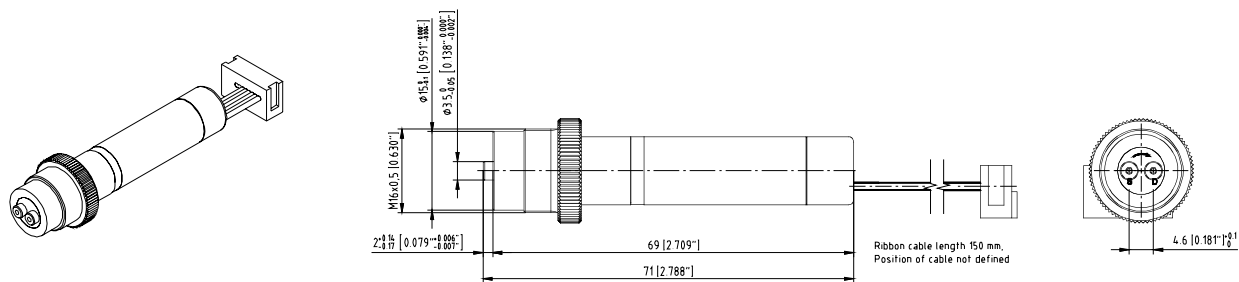

figure 2 Measurements of the micro annular gear pumps mzs-2521 and mzs-2921 with the manifold assembly

1.4 Flow charts

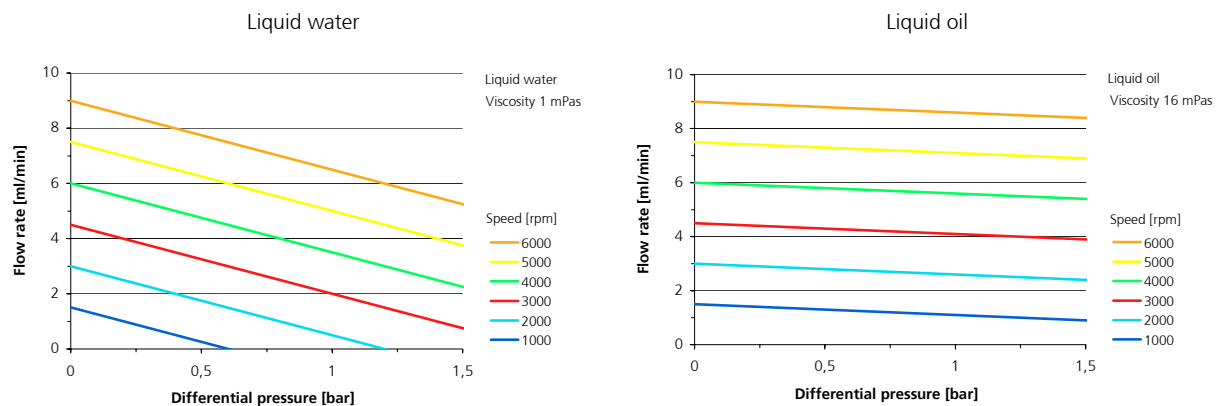

figure 3 Flow charts of mzs-2521

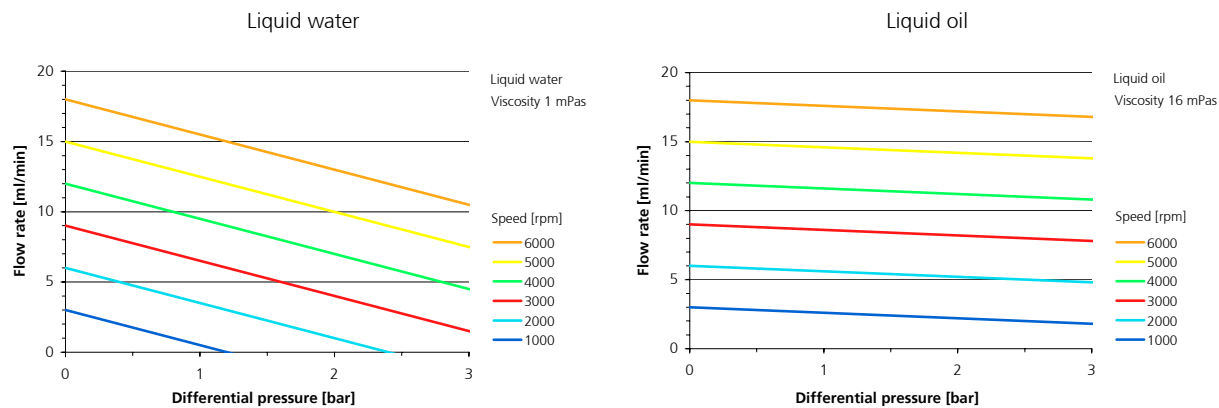

figure 4 Flow charts of mzs-2921

1.5 Technical data of the micro annular gear pump m zr-2521 and m zr-2921

	m zr-2521	m zr-2921
Technical data		
Displacement volume	1.5 µl	3 µl
Housing length without fluid connections	69 mm	69 mm
Housing length with fluid connections		
– slip fitting version Ø 2 mm	75 mm	75 mm
– manifold assembly version	71 mm	71 mm
Diameter	13 mm	13 mm
Weight		
– slip fitting version Ø 2 mm	56 g	56 g
– manifold assembly version	65 g	65 g
Internal volume	65 µl	67 µl
Housing material	stainless steel 316L (1.4404), epoxy resin adhesive	stainless steel 316L (1.4404), epoxy resin adhesive
Fluid connector material	stainless steel 316L (1.4404)	
Rotor material	tungsten carbide (WC-Ni)	
Bearing material	tungsten carbide (WC-Ni) / ceramics	
Dynamic sealing	graphite-reinforced PTFE, stainless steel spring 316L	
Static sealing	FKM; optional EPDM, FFKM	
Performance parameters		
Min. flow rate Q (at 1 rpm)	0.0015 ml/min*	0.003 ml/min*
Max. flow rate Q (at 6000 rpm)	9 ml/min (= 0.54 l/h)	18 ml/min (= 1.08 l/h)
Min. dosage volume	0.25 µl	0.5 µl
Differential pressure (at viscosity 1 mPas)	1.5 bar	3 bar
Max. applied inlet pressure	1 bar	1 bar
Viscosity	0.3 – 100 mPas (1000 mPas*)	0.3 – 100 mPas (1000 mPas*)
Dosage precision CV	1 %	1 %
Operating temperature	-20 ... 60 °C	-20 ... 60 °C
Storage temperature	10 ... 60 °C	10 ... 60 °C
Pulsation of flow (theoretical value)	1.5 %	6 %
NPSHR value	0.6 m	0,6 m

Legend: * with supplementary modules CV Coefficient of variation
NPSHR Net Positive Suction Head Required

table 1

Technical data and performance parameters of the micro annular gear pumps m zr-2521 and m zr-2921

Warning

The material property of a liquid (e.g. viscosity, lubricating property, particle content, corrosiveness) impacts the technical data and the service life of pumps.

At appropriate conditions the characteristic values may be increased or decreased.

Warning

If you intend to operate the pump out of the range of the above given specification, please consult the manufacturer. Modifications may be necessary to ensure successful operation. Otherwise the pump or the system may be damaged seriously.

1.6 Technical data of the drive

The micro annular gear pumps mzs-2521 and mzs-2921 are driven by DC motors with graphite brushes. The motors are highly dynamic and suitable for programmed dosage tasks performed by the micro annular gear pump.

Measurements	
Diameter of the motor housing	13 mm
Length of the motor housing	42 mm
Performance parameters	
Nominal voltage	18 V
Max. continuous torque	2,47 mNm
Power	3 W
No-load speed at 18 V	12,800 rpm
No-load speed at 9 V	6000 rpm
Max. continuous current	217 mA
Terminal resistance	21.5 Ω
Speed constant	738 rpm/V
Terminal inductance	0.75 mH
Speed range	1 – 6000 rpm
Cable length	150 mm

table 2 Technical data of the micro annular gear pumps mzs-2521 and mzs-2921

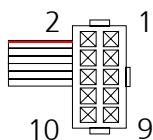

figure 5 Pin configuration of the connection socket

Pin	Description
1	Motor +
2	Vcc (5 VDC)
3	Channel A
4	Channel B
5	SGND
6	Motor –

table 3 Pin configuration of the motor

The standard motor is delivered with a 16 counts per turn digital magnet encoder.

Encoder	
Voltage supply V_{cc}	3.8 – 24 VDC
Number of channels A, B	2
Counts per turn	16
Output signal $V_{cc} = 5$ VDC	compatible TTL
Power consumption at $V_{cc} = 5$ VDC	max. 8 mA
Phase difference	90°
Operating temperature	-20 ... + 80°C

table 4

Technical data of the digital magnet encoder

The motor can alternatively be delivered:

- with a gear box module as reduction gears (see chapter 5.1)
- without encoder (see chapter 5.3)
- with a high resolution encoder 256 counts per turn (see chapter 5.4)
- with a stepper motor (see chapter 5.5)
- with a 6-pole connection plug (see chapter 6.7)

2 Safety instructions

Please comply not only with the general safety instructions listed below, but also with specific safety instructions mentioned in the following chapters.

2.1 Safety symbols in this operating manual

Non respect of the safety instructions marked with the following signs represents danger to *people*:

Danger symbol



Safety symbol according to
DIN 4844 – W9

High voltage symbol



Safety symbol according to
DIN 4844 – W8

Non compliance with the safety instructions marked with the following sign represents a risk of damage to the *micro annular gear pump*:

Warning

Operating instructions machined directly on the pump such as the indication of liquid input and output should be followed and kept in a clearly readable condition.

2.2 Staff qualification and training

The staff operating, servicing, inspecting and assembling the pumps must evidence the appropriate qualification for these works. Areas of responsibility and competence as well as monitoring of the staff must be precisely regulated by the operator in charge. If the personnel do not have the necessary knowledge, they must be trained and instructed accordingly. If necessary, this can be implemented by the supplier or the manufacturer on behalf of the operator. Furthermore, the operator in charge must ensure that the content of the present manual has been fully understood by the personnel.

2.3 Safety-conscious work

The safety instructions listed in this operating manual, applicable national regulations concerning accident prevention as well as internal work, operation and safety regulations of the operator must be complied with.

2.4 Safety instructions for the operator

The surface temperature of the motor under full load may exceed 60°C. If needed, this surface should be protected on site against contact in order to avoid skin burns.

The drive should be protected against dust, water vapor condensation, humidity, splash water, aggressive gases and liquids. Please provide for an adequate air ventilation and thus cooling of the motor.

The micro annular gear pumps m zr-2521 and m zr-2921 must not be used in areas exposed to explosion risks or in proximity of inflammable gases and vapors.

Possible leaks of dangerous liquids (for example from the shaft sealing) should be guided away in a way not to represent any danger for the personnel and the environment. The pump should be regularly checked for possible leakage. All legal requirements in this matter should be complied with.

Take care that all risks resulting from the electric energy are excluded. For details please refer to the instructions provided by the authorities in charge or your power supplier.

Warning

Please insure, that the totality of the liquid supply system such as tubes, hoses, filters etc. are free from dust or dirt particles. Impurities such as metal swarf, plastic or glass splinters may impair or damage the pump leading to its failure.

Warning

Please, operate the pump with a filter featuring 10 µm or smaller pores. It will protect the pump.

2.5 Safety instructions for maintenance, check and assembly of the pump

As a rule all maintenance work on the device should be performed when it is at a standstill. The turning-off procedure described in this manual must be followed. Pumps delivering liquids hazardous to health must be decontaminated. Immediately after the work had been completed all safety equipment and protection measures should be applied.

Before starting the operation, please take notice of the instructions listed in the chapter 7.

Warning

Should a malfunction of the m zr-pump occur, do not dismantle the pump on your own but contact one of HNP Mikrosysteme service staff for professional assistance.

2.6 Unauthorized pump conversions and spare part manufacture

Conversions or modification to the device are only permitted with prior consent of the manufacturer. Original spare parts and accessories authorized by the manufacturer ensure safety. The use of other parts will annul the liability of the pump manufacturer for any resulting consequences.

2.7 Improper modes of operation

The safety of operation of the delivered device can only be insured by correct use, as described in chapter 1. The limit values given in this manual must not be exceeded in any case.

2.8 General safety instructions

Please observe the following safety instructions



The pump may operate at high pressures. For this reason please use only the delivered accessories and ensure that the employed fittings and tubing have been prescribed and approved for these pressures.



In order to decrease the pressure, provide the system with a pressure control valve directing the excess liquid to the initial tank or back onto the suction side.



At a standstill, the liquid may flow through the pump in the direction of falling pressure. In order to avoid this unwanted movement, please integrate non-return valves (see accessories). This applies also to elevated liquid containers.



Protect the micro annular gear pump and the electric drive against strokes and shocks.



Under normal working conditions the shaft sealing rings integrated in the pump prevent the liquid from leaking out of the device. The micro annual gear pumps are "technically leak-proof" however not "hermetically sealed" which means it may occur that gases or liquids enter to or escape from the pump.



The allowed electrical parameters of the drive must not be exceeded. In particular an incorrect polarity setting of the supply voltage may lead to damage of the control unit.

Warning

Please insure, that the totality of the liquid supply accessories such as tubes, hoses, filters etc. are absolutely free from dust or dirt particles. Impurities such as metal swarf, plastic or glass splinters may impair or damage the pump leading to its failure.

Warning

Please, operate the pump with a filter featuring 10 µm or smaller pores. It will protect the pump.

3 Transport and intermediate storage

3.1 Shipment of the pumps and protection measures

The pumps leaving the factory are secured against corrosion and shocks. The inlets and outlets of the pumps are protected with plastic plugs in order to prevent any foreign bodies from penetrating into the device.

3.2 Transport

In order to avoid any transport-related damage, the package must be protected against shocks. HNP Mikrosysteme guarantees that all goods leave the factory in the best condition. Any noticed damage should be reported to the concerned forwarding agent, authorized dealer or to HNP Mikrosysteme as manufacturer.

3.3 Intermediate storage

Following points concerning pump storage should be observed:

- necessary conservation procedure (see also chapter 7.4.1)
- the protective caps must be put on
- the pump should not be stored in humid places
- for storage temperature - refer to chapter 1.5 of the present manual

4 Description of the micro annular gear pump

4.1 Operating principle of the micro annular gear pump

Micro annular gear pumps are positive displacement pumps. They contain two rotors bearing slightly eccentrically to each other; an externally toothed internal rotor and an annular, internally toothed external rotor (see figure 6). Due to their cycloid indenting, the rotors remain interlocked at any time, forming during rotation a system of several sealed pumping chambers. As the rotors revolve around their offset axis, the pumping chambers increase on the induction (suction) side and simultaneously decrease on the delivery side of the pump (see figure 7). A homogenous flow is generated between the kidney-like inlet and outlet.

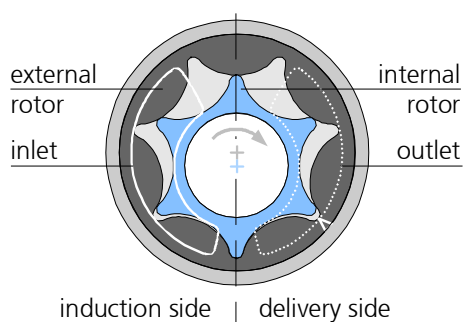

figure 6

Principle of the micro annular gear pump

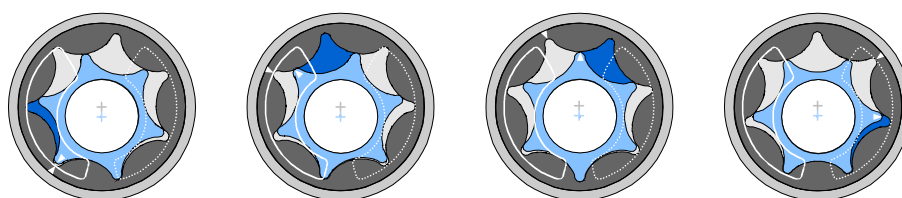

figure 7

Operating principle of the micro annular gear pump

In the case of rotary displacement pumps, the delivered amount of liquid may be easily calculated from the displacement volume V_g of the pump and the number of revolutions of the rotor n . Displacement volume stands for the volume of liquid that is moved within one revolution cycle of the rotor. This relation is illustrated by the following formula:

$$Q = \eta_{Vol} \cdot V_g \cdot n$$

The volumetric efficiency η_{Vol} shows the relation between the actual and the theoretical flow rate values. The existing differences result from internal movement of the liquid during the operation.

Example: According to the formula mentioned above the m zr-2521 pump featuring a displacement volume of 1.5 μl , delivers at 3000 rpm and with a volumetric efficiency of 100% 4.5 ml/min. The table 5 shows theoretical flow rate values depending on speed expressed in ml/min and ml/h.

Speed [rpm]	m zr-2521		m zr-2921	
	Q [ml/min]	Q [ml/h]	Q [ml/min]	Q [ml/h]
500	0.75	45	1.5	90
1000	1.5	90	3	180
2000	3	180	6	360
3000	4.5	270	9	540
4000	6	360	12	720
5000	7.5	450	15	900
6000	9	540	18	1080

table 5

Theoretical flow rate of the micro annular gear pumps m zr-2521 and m zr-2921

The pressure generated by the pump is determined by the configuration of the liquid delivery system and results from both the hydraulic pressure and the hydraulic resistance (tubing, narrow passes etc.). The *volumetric efficiency* of the pump decreases when the differential pressure rises.

The *viscosity* of the handled liquid has an important impact on the volumetric efficiency. The volumetric efficiency increases for higher viscosity values because the internal leakage values go down.

Cavitation is an effect which, starting from a certain limit speed value, may reduce the volumetric efficiency of a pump. In the case of high viscosity liquids this limit speed value is lower. That happens because of the liquid-specific drop of vapor pressure in the induction (suction) tube which leads to gas formation inside the pump.

The particularity of the m zr-pumps is their highly precise construction design, which provides for both high operating pressures and a high dosage precision. The gap between both rotors and between the rotors and the adjacent case parts lies in the range of a few micrometers. This precision is the key factor enabling to achieve volumetric efficiency close to 100%.

4.2 Construction

The micro annular gear pump (figure 8) is composed of the pump head, the drive unit and the connection cable with plug. The micro annular gear pump head is available with two different fluid connection versions.

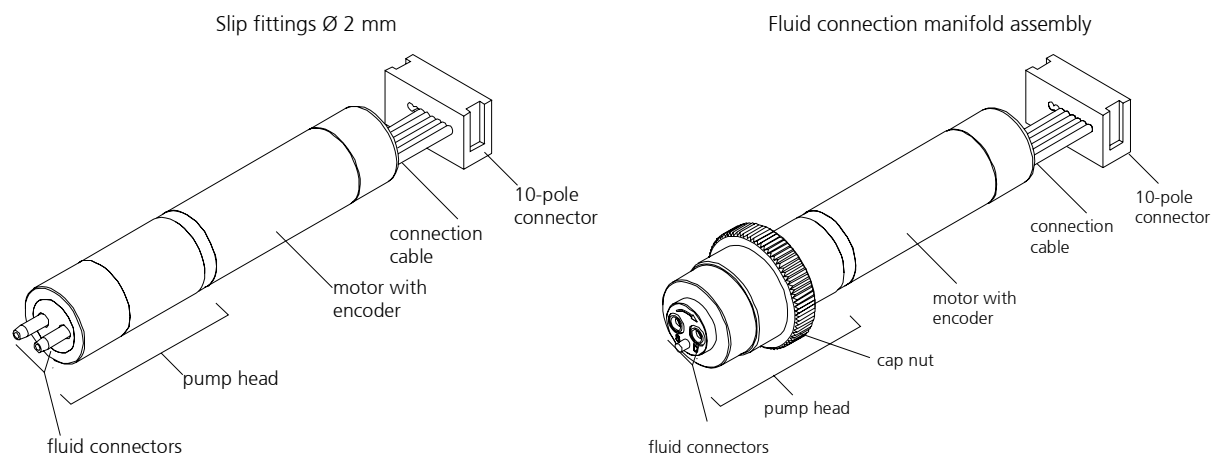

figure 8 Layout of the micro annular gear pumps mzs-2521 and mzs-2921

4.3 Construction materials

Wetted parts	Construction material
Housing	stainless steel 316L (1.4404) (optional: nickel silver), epoxy resin, adhesive
Fluid connectors	stainless steel 316L (1.4404)
Rotors	tungsten carbide (WC-Ni)
Bearing	ceramics and tungsten carbide (WC-Ni)
Dynamic sealing (shaft sealing)	graphite-reinforced PTFE, spring: stainless steel 316L
Static sealing (O-rings)	FKM (fluoroelastomer), optional EPDM, FPM (perfluoroelastomer)

table 6 Construction materials of the wetted parts mzs-2521 and mzs-2921

Resistance of the construction materials to the delivered liquids should be verified by the operator for each individual application. For non-lubricating liquids service life of the pumps is shorter.

4.4 Liquid supply

The micro annular gear pump head is available with two different liquid connector versions.

Slip fittings

The micro annular gear pump head is equipped with two front slip fittings with OD 2 mm for connection of flexible tubes with the ID < 2 mm (such as 1/8" hose).

The suction side is indicated with the letter »S« the delivery side with the letter »D«. An arrow in the front of the pump indicates the operating direction of the shaft.

In order to prevent foreign bodies from penetrating into the pump, the liquid inlet and outlet are protected by plastic caps. Please remove them before you assemble the pump.

Manifold assembly

The micro annular gear pump with manifold assembly has been designed for integration into systems. The benefit of the manifold assembly is diminished cubage for easier integration of the micro annular gear pump and higher pressure resistance.

The dimensions for installation are given in the figure 9 and the position of the gaskets in the figure 10.

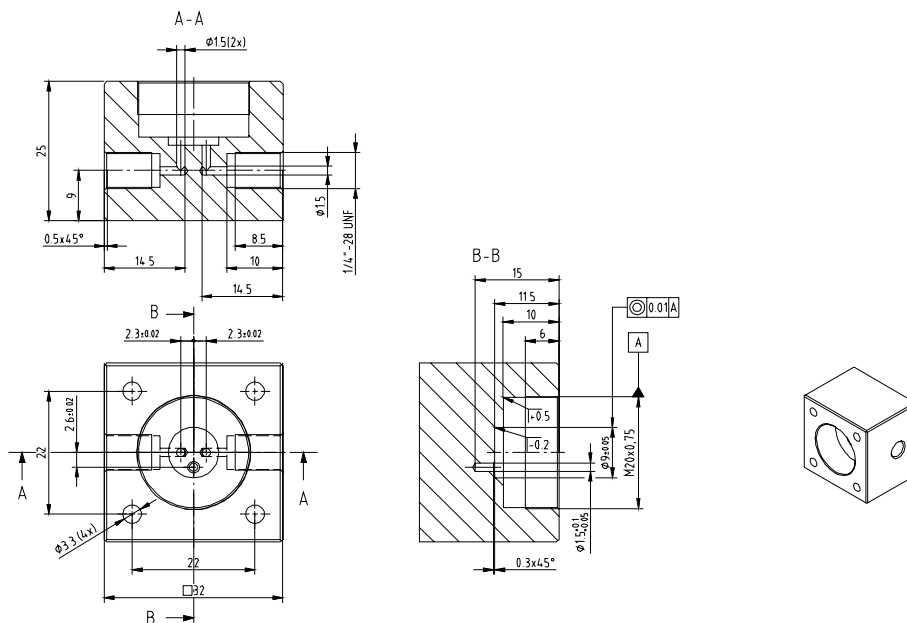

figure 9 Dimensions for installation

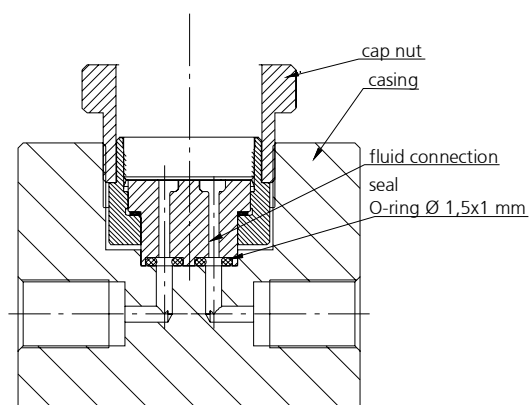

figure 10 Pump after installation with both gaskets

In order to prevent foreign bodies from penetrating into the pump, the liquid inlet and outlet are protected by plastic plugs or screws.

5 Optional modules

The spectrum of applications of the low pressure micro annular gear pump series may be expanded by using different additional modules. The modules allow for special dosage tasks, which could otherwise not be accomplished with a standard pump version. The modules may be combined with each other and with almost all available pump heads and motor versions.

- Gear box module increases the torque of the drive allowing to deliver highly viscous liquids and provides for a constant operation of the motor at low speeds (see chapter 5.1).
- By-pass module for the delivery of minimal constant flow rates down to the nanoliter range (see chapter 5.2)
- Drive without encoder (see chapter 5.3)
- Drive with high resolution encoder enables constant operation of the motor at very low speeds (see chapter 5.4)
- Stepper motor as drive (see chapter 5.5)
- Brushless DC-motor (BLDC) as drive (see chapter 5.6)

Due to specific requirements of each application the configuration of a given pump version should be discussed with the technical service. Additional customized modules may be designed on demand.

5.1 Gear box module (optional)

The gear box module enables to operate the pump at very low speeds and increases the torque of the motor for the delivery of highly viscous liquids or for application with increased operating pressure. The gear box module is available with the following reductions: 4.1 : 1, 17 : 1, 67 : 1 and 275 : 1 in combination with the pump heads mzr-2521 and mzr-2921. The length of a micro annular gear pump with the gear box module increases by 16 mm to 28 mm (see table 7). For pumps with the gear box module the position of the slip fittings to the connection cable is undetermined.

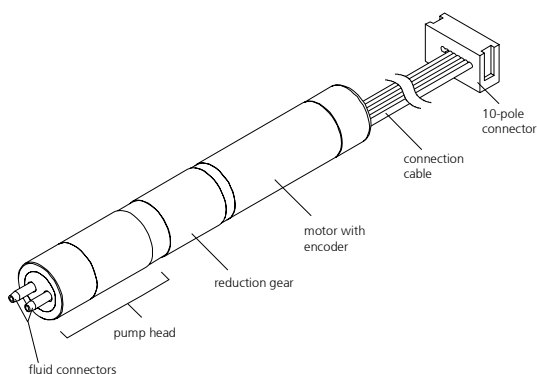

figure 11 Micro annular gear pump mzr-2921 with the gear box module

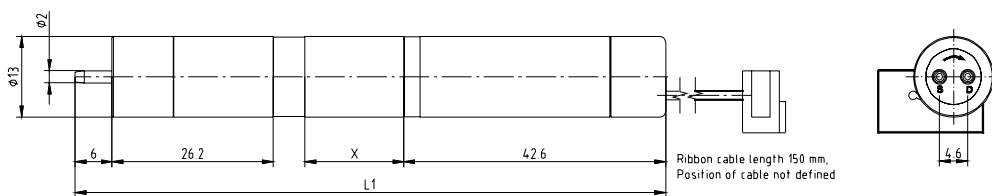

figure 12 Measurements of the micro annular gear pump mzr-2521 or mzr-2921 with the gear box module

Gear reduction	Length of the gear box	Total length of the pump L1	Weight of the gear box
4.1 : 1	16.1 mm	96.1 mm	11 g
17 : 1	20.0 mm	100.0 mm	14 g
67 : 1	23.8 mm	103.8 mm	17 g
275 : 1	27.7 mm	107.7 mm	20 g

table 7 Measurements of the gear box modules

Gear reduction	Max. pump speed (recommended max. motor speed 8000 rpm)
4.1 : 1	1950 rpm
17 : 1	470 rpm
67 : 1	119 rpm
275 : 1	29 rpm

table 8 Maximal pump speed with the gear box modules

5.2 By-pass module (optional)

The by-pass module allows constant minimal volume dosage with flow rates in the nanoliter range. The technology is based on the division of flow generated by the micro annular gear pump, according to the relationship of fluidic resistance of two predefined capillaries. The micro annular gear pump generates a master circulation from which a side dosage current is derived. This micro flow capillary allows to obtain flow rates starting at 1 $\mu\text{l/h}$. The minimal and the maximal flow rate may differ by a factor of 1000 (dynamic factor). In order to determine the lower flow rate limit, both capillaries need to be carefully configured. It is possible to obtain flow rates between 1 and 10,000 $\mu\text{l/h}$.

The by-pass module assures dosage of minimal amounts of liquids at a very high constancy of flow and a pressure-resistant flow rate.

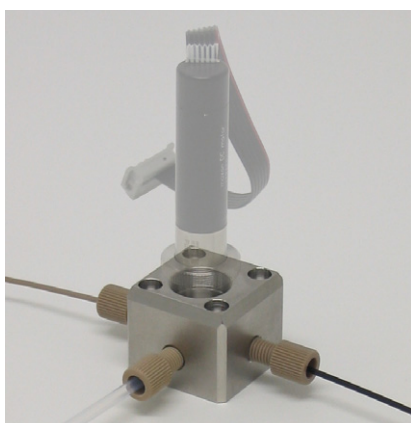

figure 13

The by-pass module

Performance parameters	
Operating flow rate range	1 – 10,000 $\mu\text{l/h}$
Differential pressure range	0 – 3 bar
Max. applied inlet pressure	1 bar
Pulsation	<1 %
Operating temperature	-20 ... +60 °C
Viscosity range	0.5 – 100 mPas
Fluid connections	– Liquid intake: tube or hose, OD 1/8" – Master capillary: tube, OD 1/8" (return line to the tank) – Side current capillary: tube, OD 1/16" (dosage capillary)
Wetted parts	stainless steel 316L, PEEK
Measurements	□ 32 x 25 mm (by-pass module without pump)
Weight	approx. 140 g (by-pass module without pump)

table 9

Technical data of the by-pass module

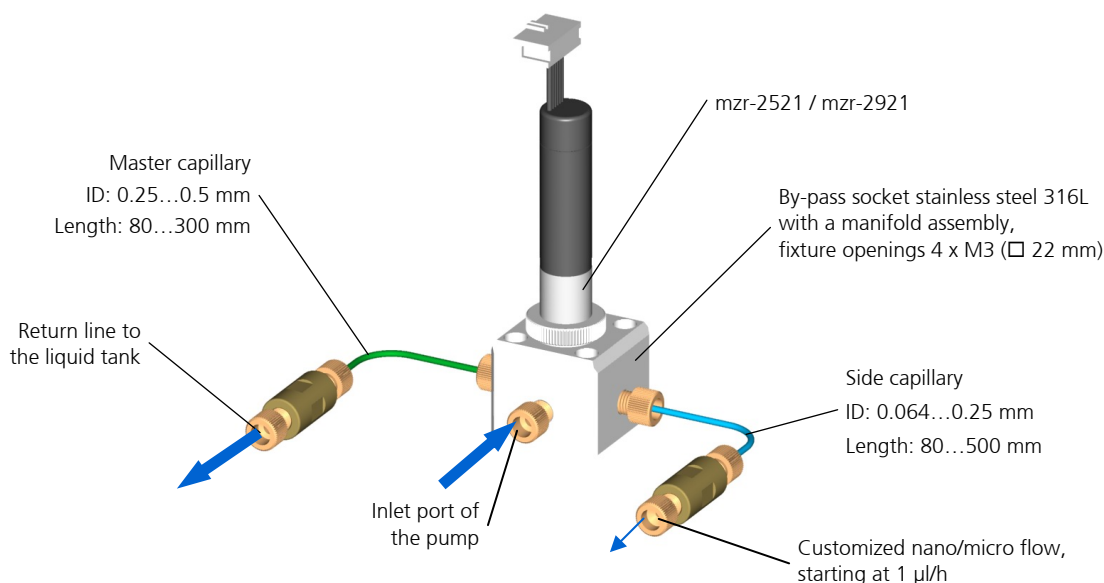

figure 14

Construction of a by-pass module

Working principle

The by-pass module shown in the figure 14 divides the flow generated by the micro annular gear pump into master and side circulation. The module serves at the same time as a support and fixture for the micro annular gear pump. The selection and configuration of the different components of the system is calculated by a PC. The master circulation capillary (the tube going back to the liquid tank) and the pump are selected and configured for each customer-specific dosage task. In this way the pump operates with the desired volumetric efficiency and can generate pressures reaching beyond the required pressure level. Depending on the difference of pressures between the delivery side of the pump and the system, a side current capillary is designed and precisely adjusted so that the desired minimal flow rate is obtained at its outlet. The flow charts of the by-pass module are verified before the shipment.

Flow chart examples

Flow rate range 100 – 9000 µl/h

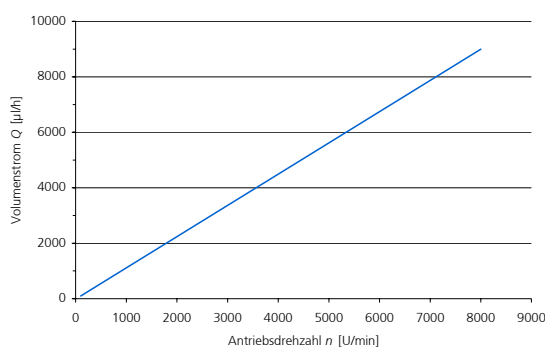

Flow rate range 0.6 – 4.4 µl/h

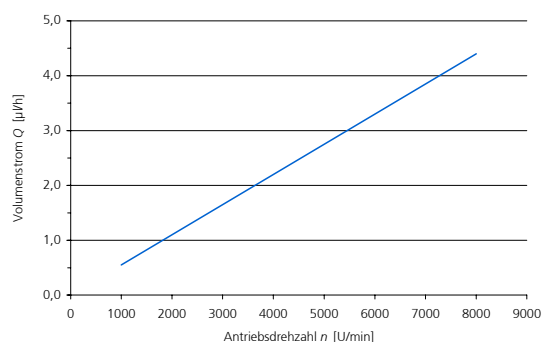

5.4 Drive with a high resolution encoder (optional)

The high resolution 256 counts per turn digital MR-encoder enables to operate the pump at low speeds, starting at 1 rpm and allows at the same time a very constant motor operation.

Encoder	
Supply voltage Vcc	5 VDC
Number of channels A, B, I	3
Counts per turn	256
Output signals at Vcc = 5 VDC	TTL compatible
Power consumption per channel	max. 5 mA
Phase shift	90°
Operating temperature range	-25 ... + 85 °C

table 10 Technical data of the high definition MR-encoder

Micro annular gear pumps mzs-2521 and mzs-2921 with a high resolution encoder have the same measurements as a standard pump.



Please pay attention to the changing encoder setting during the programming and adjustment of the micro annular gear pumps.

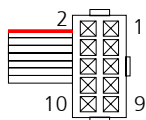

figure 16 Pin configuration of the connection socket

Pin	Description
1	Motor +
2	Vcc (5 VDC)
3	Channel A
4	Channel B
5	SGND
6	Motor -
7	Channel I

table 11 Pin configuration of the motor

5.5 Stepper motor drive (optional)

The micro annular gear pump mzs-2521 and mzs-2921 can alternatively be driven by a stepper motor. This motor is characterized not only by small dimensions but also by a large speed range, which perfectly covers the operating speed range of the pumps.

Stepper motor	
Operation	Current mode
Motor type	AM1524 A 0.25
Speed range	1 – 3000 rpm
Phase resistance (at 20°C)	12.5 kΩ
Inductance per phase (1 kHz)	5.5 mH
Nominal current per phase (2 current phases)	0.25 A
Back -EMF amplitude	3.5 V/k steps/s
Holding torque (2 current phases)	6 mNm
Step angle (full step)	15°
Max. allowed winding temperature	130 °C
Thermal time constant	220 s
Operating temperature range	-40 ... + 70 °C
Weight	12 g

table 12 Technical data of the stepper motor

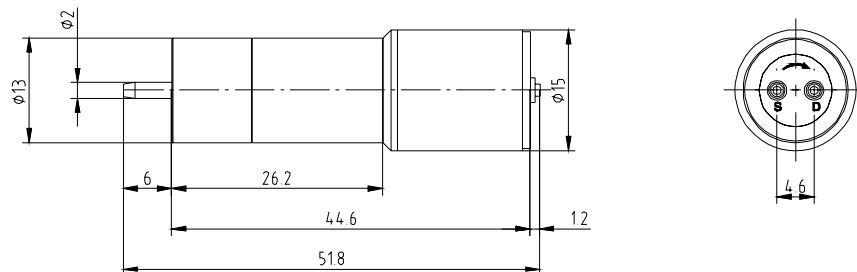

figure 17 Measurements of the micro annular gear pump mzs-2521 and mzs-2921 with the stepper motor

The stepper motor can be operated with an adapted control unit. For this purpose the motor should be connected with a ribbon cable to the solder joint of the control unit.

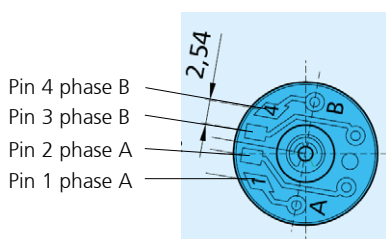

figure 18 PCB of the round stepper motor version

5.6 Brushless DC motor as drive (option)

The micro annular gear pump mzs-2521 and mzs-2921 can alternatively be driven with a brushless DC-motor. It is characterized by higher dimensions and a wider speed range, which covers entirely the speed range of the micro annular gear pump and shows a longer service life than a brushed DC-motor.

Performance parameters	
Nominal voltage	24 V
Max. continuous torque	2.6 mNm
Power	11 W
No-load speed at 9 V	11,583 rpm
Max. continuous current	0.41 A
Terminal resistance, phase-phase	15.1 Ω
Terminal inductance, phase-phase	525 μ H
Speed	1 – 6000 rpm
Ambient temperature	-30 ... +125 $^{\circ}$ C
Type of Hall effect sensor	analog <input type="checkbox"/> digital

Legend: Option for the S-KB control unit

table 13

Technical data of the brushless DC-motor

Function	Connection	Color
Hall sensor	A	green
Phase	A	brown
Hall sensor	B	blue
Phase	B	orange
Hall sensor	C	gray
Phase	C	yellow
Voltage	+5 V	red
Mass	GND	black

table 14

Pin configuration of the motor

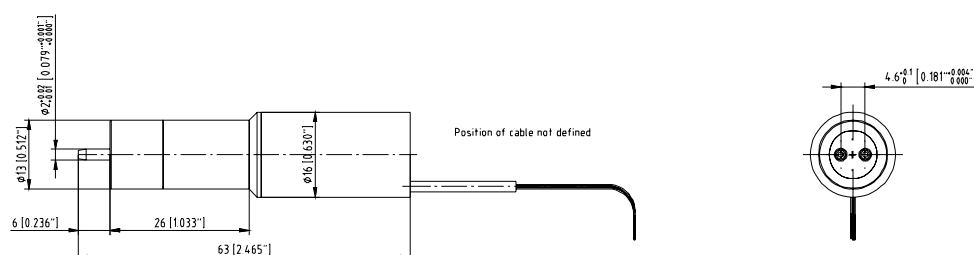

figure 19

Measurements of the micro annular gear pump mzs-2521 or mzs-2921 with a brushless DC-motor



Please notice that the brushless DC motors must imperatively be operated with an adapted control unit! The micro annular gear pumps mzs-2521 and mzs-2921 can be delivered for this purpose with optional control units S-BL.

6 System integration

6.1 Checkup before the first assembly

Inspect the pumps for potential damage during the shipment (see chapter 3.2).

Please check according to the following points if the right pump type has been delivered:

- Compatibility with the delivered liquid
- Viscosity range
- Pump performance (displacement volume, dosage volumes, operating pressures)
- Operating temperature range



If you notice any difference between the required and the delivered pump type, please contact HNP Mikrosysteme. Do not put the pump into operation without prior approval.

6.2 Mounting of the micro annular gear pump

The favored mounting position of the micro annular gear pump is horizontal. However, if the pump has to be operated vertically, the motor must be located above the pump head in order to prevent the liquid from entering into the motor.

The pump may be installed on a plastic or stainless steel cable screw M20.

Warning

Install the pump in such a way that in case of failure no liquid can enter to the motor or controller.



If the pump is mounted flexibly or dosing tasks require change of pump position, please fasten the cable with an adapted cable tie at the motor in order to avoid strain. If the pump is moved over a longer time, the cable may break at its connection to the motor.



Take precautions that in case of leakage no surrounding objects or environment will be exposed to danger.



The motor must be protected against humidity, dust or sweat.

6.3 General instructions for the assembly of the liquid supply network

Foreign bodies and dirt particles can block the micro annular gear pump and lead to its damage.

Warning

Please note that all the components of the liquid supply system should be clean and flush them if needed before pump installation. Remember to remove all remaining splinters or swarf from connection fittings, rests from liquid containers and any dirt from valves, tubing and filters.

Warning

Operate the pump with a filter featuring 10 µm or smaller pores. The filter protects the pump from particles and dirt.



If the pump is connected once again with a hose that has already been used, the enlarged ending of the hose should be cut off in order to prevent it from slipping off and the liquid from flowing out of the connection.

Assembly of the fluid connection fittings

Cut the hose to a right angle by using an adapted hosecutter.

Warning

Remove the protection caps from the slip fittings of the pump.

If needed, warm up or widen the hose and slip it on the slip fitting till it touches to the housing.



Pay attention to the correct assembly of the tubing and the pump head in order to keep the default direction of flow. If you wish to operate the pump in a reverse direction, please contact one of HNP Mikrosysteme's application engineers since it is not possible in every case.

The intake tubing should be kept as short as possible and have a possibly large internal diameter in order to assure best intake performance.

In order to avoid dry operation, check before each use that enough liquid is supplied to the pump.

Warning

Dry run of the micro annular gear pump may damage in particular the bearing and the sealing. However, a short dry working phase at the beginning of the operation is harmless.

Installation with the manifold assembly

1. Put the pump in the desired position for installation. Ensure that the intake and the delivery fluid connections have not been inverted.

Warning

Check if the o-ring 1.5 x 1 mm lay correctly and are not damaged.

2. Screw on the holding nut.

3. In order to avoid dry operation of the device, provide before each operation for a sufficient liquid supply.

Warning

Dry run of the micro annular gear pump may damage in particular the bearing and the sealing. However, a short dry working phase at the beginning of the operation is harmless.

6.4 Filter selection and use

In majority of cases it is recommended to integrate a filter on the suction side of the micro annular gear pump to ensure its secure operation. The recommended filter pore or mesh size should not exceed 10 µm. The penetration of particles or swarf that could cause a blockage or damage to the pump can only be avoided by using an adapted filter.

HNP Mikrosysteme offers a choice of standard filters covering a broad spectrum of applications. You may count on our assistance for the selection of the most suitable filter.

In order to select the best adapted filter, such operating parameters as the flow rate, the viscosity and the degree of pollution of the liquid will be needed. An increase in at least one of the mentioned terms will require the use of a bigger filtering element or pressurization of the delivered liquid. In case no suitable filter for the given high-viscosity liquid can be found, it is possible to use a filter with slightly larger pore size. Prior discussion with HNP Mikrosysteme is here recommended. A filter with larger pores is still better than no filter at all. As an alternative solution an already filtered liquid may be used.

Warning

Because filters have a large internal volume, it is recommended to fill in the filter and the induction (suction) tubing with already filtered liquid in order to avoid a too long dry run of the pump during the first operation.

Warning

Please control regularly the filtering elements for pollution. Cleanse regularly the filter or replace it with a new one. A polluted filter may considerably decrease the volumetric efficiency of a pump. Furthermore, because of the cavitation effects dosage imprecision and even pump damage may occur.

Warning

A too small filter (too little filtering surface) may considerably decrease the volumetric efficiency of the micro annular gear pump. What is more, because of the cavitation effects dosage imprecision and even pump damage may occur.

6.5 Operation with the S-ND control unit

The micro annular gear pumps mzs-2521 and mzs-2921 may optionally be delivered with the S-ND control unit. This programmable control unit enables to adjust speed for constant flow rates or the position of the motor for the dosage of constant amounts of liquid. On the delivered diskettes or CDs you will find a PC-program operating under Windows that enables to program such parameters as speed, acceleration and current consumption. The delivery package comprises also a null-modem cable for connection to a serial interface of a PC.

S-ND control unit			
Type of control unit		4-Q servo amplifier	
Nominal voltage	U	24	V
Power supply	U _B	12 - 30	V
Residual ripple		≤ 2 %	
Max. continuous output current	I _{continuous}	230*)	mA
Max. peak output current	I _{max}	400*)	mA
Speed range		10...6000*)	rpm
Input No. 1	input resistance	5	kΩ
Nominal analog speed	voltage range	± 10	V
Nominal digital speed	PWM signal	low 0...0.5 / high 4...30	V
	frequency range	100...2000	Hz
Input No. 2	open collector	max. U _B / 30 mA	
	no error	switched to GND	
	programmed as input	low 0...0.5 / high 3,5... U _B	V
Input No. 3, 4, 5	TTL - logic level	low 0...0.5 / high 3,5...30	V
	PLC - logic level	low 0...7 / high 12,5...30	V
Program memory		6,6	kBytes

*) Values limited in the control unit with corresponding software

table 15

Technical data of the S-ND control unit

The control unit permits an easy startup of the pump with:

- the possibility to connect the voltage supply to the delivered DIN socket
- the possibility to connect the voltage supply with screw clamps
- a 10-pole connector assembly for the motor cable
- speed set with potentiometer
- analog voltage signal 0-10 V for speed control at the screw clamps
- 9-pole connection plug for the RS-232 interface
- error output with status LED, programmable also as trigger input with screw connections
- tumbler switch S1 for the connection of digital input No. 3 of the motor control unit
- screw clamps for the connection of digital inputs No. 3, 4, 5 of the motor control unit

Startup of the micro annular gear pump with the S-ND control unit

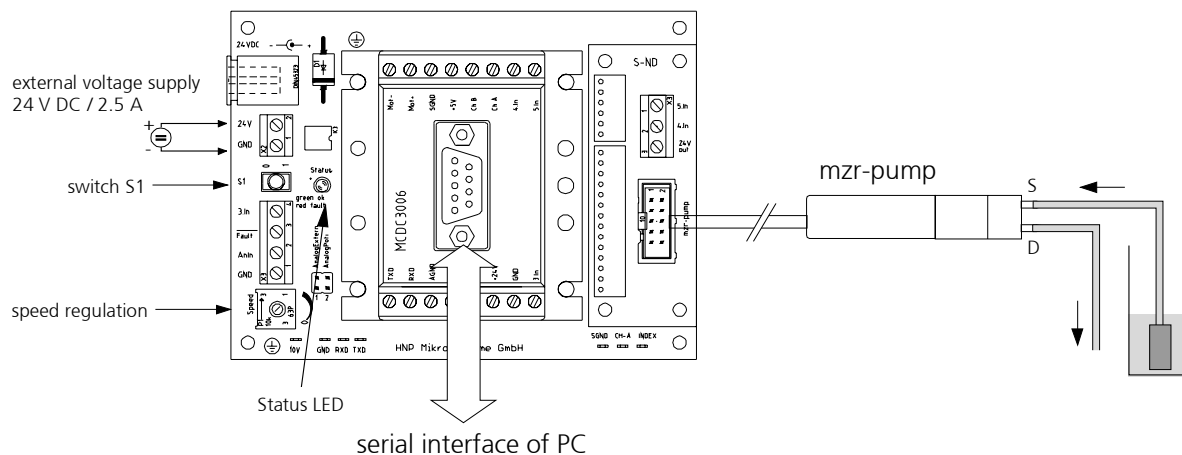

figure 20

Connection of the micro annular gear pump mzs-2521 or mzs-2921 and the S-ND control unit

1. Connect the motor cable to the 10-pole connector of the S-ND control unit. The pin configuration is indicated in table 3.
2. Connect the RS-232 port of the MCBL3006 with a free serial interface of a PC. For this purpose use the delivered 9-pole null-modem cable.
3. Put the potentiometer of the S-ND control unit to zero position by turning it clockwise to the limit stop.
4. Connect the voltage supply 24 VDC. This can be done with the integrated DIN connector or, alternatively the 2-pole screw clamp (24 V = »+«; GND = »-«). Pay attention to the correct polarity.
5. You may now install the delivered software as described in the chapter 8 or 9.



While connecting the DC voltage pay attention to the correct polarity, otherwise electronics may be damaged.

Remarks:

- It is possible to adjust speed of the micro annular gear pump with the potentiometer without the need to connect the serial interface.
- With the analog nominal value input (connection clamps »AnIN« and »GND«) it is possible to adjust speed of the pump with a standard signal 0-10°V. For this purpose it is necessary to plug the jumper on the S-ND control unit from the »AnalogPoti« to the »AnalogExtern«. The serial interface does not need to be connected.
- In case of an overcurrent error the green status LED on the S-ND control unit turns red
- The standard programs memorized in the motor control unit may be started with the tumbler switch S1. Basic sample programs are shown in the chapter 7. For more advanced programs please refer to the user manual for Motion Controller MCDC3006.

Startup of the pump with the S-ND control units with network mode (NET1 Command)

All standard units are delivered with node number 0. In order to prepare the units for network operation, they must first be individually connected to the PC and set to the desired node address using the FAULHABER Motion Manager.

A serial network can be constructed using the so-called daisy-chain technique, in which the transmit cable of the Master (PC, PLC) is connected to the receive cable of the first node, from where it is looped through to the receive cable of the second node, and so on. The same procedure is followed with the receive cable of the Master, which is looped through to all transmit cables of the drive node. The current generation of Motion Controllers do not require a multiplexer board for serial network operation. The multiplex mode is activated with a command NET1.

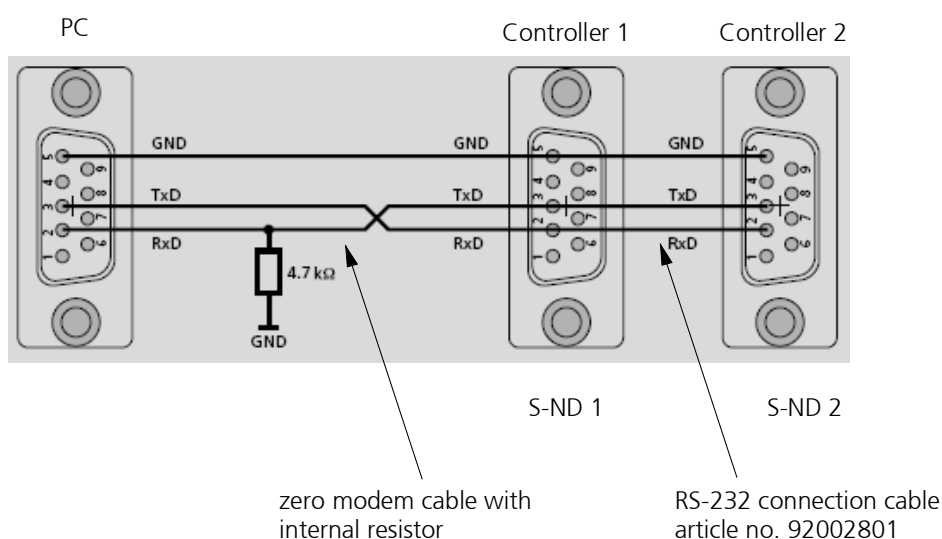

figure 21

Connection between PC, controller S-ND 1 and Controller S-ND 2

1. Connect the RS-232 port of the controller S-ND 2 with the RS-232 of the controller S-ND 1. For this purpose use the delivered 9-pole RS-232 connection cable.
2. Connect the In Port of the RS-232 connection cable with a free serial interface of a PC. For this purpose use the delivered 9-pole null-modem cable with internal resistor.
3. Connect the motor cables to the 10-pole connector of the S-ND control units. The pin configuration is indicated in table 3.
4. Put the potentiometer of the S-ND control units to zero position by turning it clockwise to the limit stop.
5. Connect the voltage supply 24 VDC. This can be done with the integrated DIN connector or, alternatively the 2-pole screw clamp (24 V = »+«; GND = »-«). Pay attention to the correct polarity.
6. You may now install the delivered software as described in the chapter 9.



While connecting the DC voltage pay attention to the correct polarity, otherwise electronics may be damaged.

Remarks:

- Controller which the manufacturer specifically shipped for the network modus were with the command NET1, SOR0, ANSW0 and DIPROG programmed.
- In order to address the individual drives in the network, the node number must be specified before each ASCII command to be sent (e.g. 2V500). Commands without a node number are adopted by all drive nodes in the network.
- No unaddressed query commands may be sent in network mode, as otherwise all units will answer simultaneously and the message frames will mix, resulting in communication errors. It must also be ensured that no asynchronous responses are sent by several units simultaneously, and that the command acknowledgement is switched off when using unaddressed transmit commands. Use the ANSW0 command to set the response behaviour.

6.6 Operation with the S-KD control unit (optional)

The micro annular gear pumps mzr-2521 and mzr-2921 may optionally be delivered with the S-KD control unit. The speed for constant flow rates may be adjusted with a 4-Q servoamplifier. The delivery comprises also a PCB for connection of the motor cable.

S-KD control unit			
Nominal voltage	U	24	V
Power supply	U_B	12 - 30	V
Residual ripple		$\leq 3 \%$	
Max. output current	I_{max}	230*)	mA
Max. output power	P_{max}	50	W
Speed range	n	200...6000*)	rpm
Nominal value input »Set Value«		± 10 or ± 3.9 configurable	V
Status signal »Ready«		Open collector max. $U_B / 20$ mA no error: »Ready« = high impedance Ready »Ready« = GND	
Connection of »Disable«		Connection of »Disable«	
Measurements		approx. 114 x 100 x 34	mm
Weight		approx. 370	g
Working temperature range		0 ... +45	°C

*) Values limited in the control unit with the potentiometer

table 16

Technical data of the S-KD control unit

The control unit enables an easy startup of the pump with:

- the connection board for 10-pole plug of the motor cable
- the possibility to connect the voltage supply to the screw clamps
- the analog voltage signal to the screw clamps for speed set

Startup of the micro annular gear pump

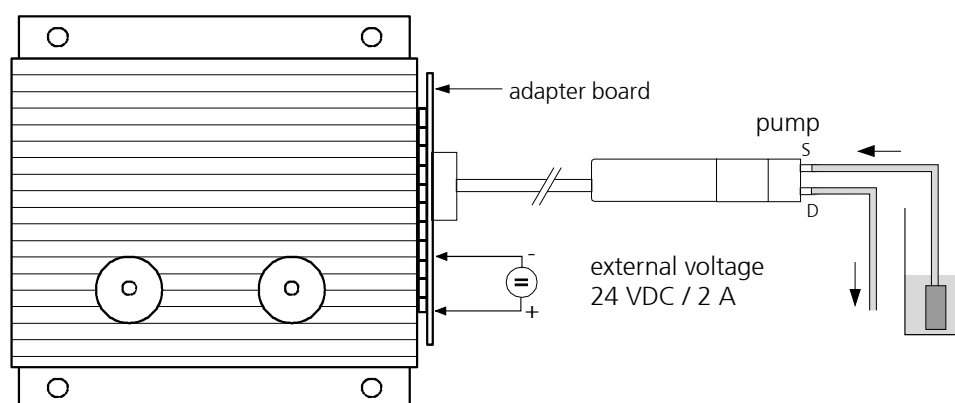

figure 22

Connection of the micro annular gear pump mzr-2521 and mzr-2921 to the S-KD control unit

Warning



At the startup of the motor control unit S-KD please pay attention to the following technical description.

At the delivery of the S-KD motor control unit with the connection board and integrated potentiometer 50 kΩ it is sufficient to connect the power supply.

1. Connect the motor cable to the 10-pole connector of the S-KD control unit. The configuration of the connection socket is described in the table 3.
2. Connect the potentiometer for speed set of the micro annular gear pump to the S-KD control unit.

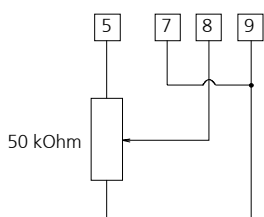

figure 23 Connection of the potentiometer to the S-KD control unit (normal operation of the micro annular gear pump)

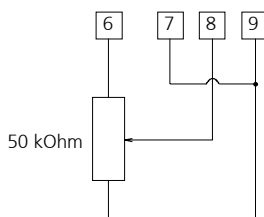
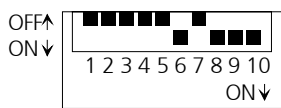
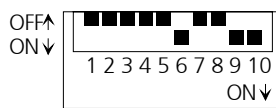

figure 24 Connection of the potentiometer to the S-KD control unit (reverse operation of the micro annular gear pump)

3. Set the jumper of the control unit according to the table 17.



Switch configuration for drive with Encoder 16 counts per turn



Switch configuration for drive with encoder 256 counts per turn

table 17 Jumper set of the S-KD control unit

Remark:

The jumpers of the control unit are preset for operation with the micro annular gear pump mzs-2521 and mzs-2921.

4. Check the position of the potentiometer (see table 18 and table 19).

5. Connect 24 VDC to the clamps. Pay attention to the correct polarity (clamp 3 = »+«; clamp 4 = »-«).

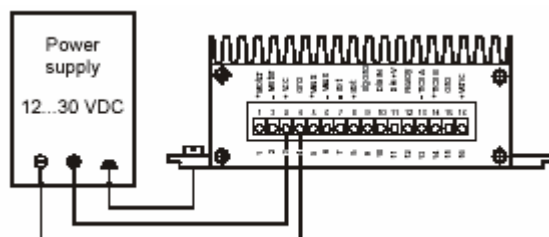

figure 25 Voltage supply of the S-KD control unit



While connecting the DC voltage pay attention to the correct polarity, otherwise electronics may be damaged.

Remark:

The internal potentiometer of the control unit is preset for operation with the micro annular gear pumps mzr-2521 and mzr-2921 and for operation with the external potentiometer.

Pin	Function	Potentiometer set
P1	n_{\max}	70 %
P2	I_{XR}	0 %
P3	Offset	50 %
P4	I_{\max}	20 %
P5	Gain	10 %

table 18 Default set of the internal potentiometer

Pin	Function	Potentiometer set
P1	n_{\max}	65 %
P2	I_{XR}	0 %
P3	Offset	50 %
P4	I_{\max}	20 %
P5	Gain	10 %

table 19 Set of the internal potentiometer in the 0 - 10 V operation

6.7 Operation with the S-KG control unit (optional)

The S-KG control unit is a compact 4-Q DC servoamplifier for speed set of brushed DC motors with a current consumption of up to 0.5 A. The operating parameters of this control unit are specially adapted to the micro annular gear pumps mzr-2521 and mzr-2921 of the low pressure series manufactured by HNP Mikrosysteme. The S-KG motor control unit based on a high capacity 16-Bit microcontroller, which may be precisely adjusted also at low motor speeds.

A set of inputs and outputs enable the user to adjust the motor control such as the nominal value input, the sense of rotation input, enable input, error output and speed signal output.

At the delivery the parameters of the control unit S-KG-21 are preset for operation with the micro annular gear pumps mzr-2521 and mzr-2921. Also the analog nominal value input of the control unit is by default preset for the potentiometer operation mode.

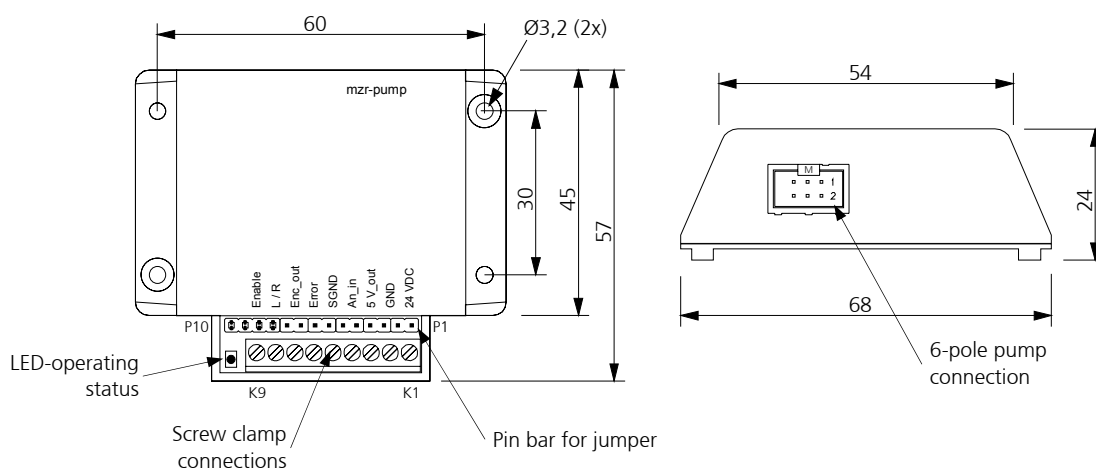

figure 26 Measurements and connection ports of the motor control unit S-KG

Technical data

General technical data			
Type of control unit		4-Q servo amplifier	
Nominal voltage	U	24	VDC
Power supply	U _B	10 - 24	VDC
Residual ripple		≤ 3 %	
Max. continuous output current	I _{continuous}	0.5 *	A
Max. peak output current	I _{max}	1	A
Total standby current	I _{el}	0.02	A
PWM switching frequency	f _{PWM}	20	kHz
Speed controller type		PID controller	
Speed range		100 ... 6000 *	rpm
Output voltage for external use	5V_out	5	V
		max. 10 mA	
Nominal input speed	An_in	10-Bit A/D-converter	
	Voltage signal	0 ... 10	V
	Potentiometer	10 kΩ (Voltage level 0 ... 5 V)	
	Current signal	4 ... 20	mA
Sense of rotation (input)	L / R	low 0 ... 0.5 / high 4 ... U _B (low for clockwise operation)	V
Enable input	Enable	low 0 ... 0.5 / high 4 ... U _B (low: Enable), (high: Enable optional)	V
Error output	Error	Open collector, max. 50 mA, high 4 ... U _B ; no error	
Speed signal output	Enc_out	Open collector, max. 50 mA, Encoder signal channel A	
Weight with housing		35	g

* Values limited in the control unit with corresponding software

table 20

General technical data

Nr.	Configuration
K1	24 VDC
K2	GND
K3	5 V_out
K4	An_in
K5	SGND
K6	Error
K7	Enc_out
K8	L / R (sense of rotation)
K9	Enable

Nr.	Configuration
M1	motor +
M2	+ 5 V
M3	channel A
M4	channel B
M5	GND
M6	motor -

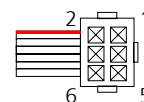

table 21

Configuration of the screw connections

Configuration of the 6-pole motor connector

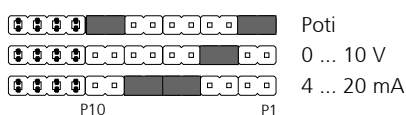

table 22

Jumper configuration for the analog speed input

LED	Meaning
green	Voltage supply to the control unit is correct, no error
blinking red	Current limitation or blockage of the motor
blinking green and red	Too high speed divergence, pump blockage or encoder error

table 23 LED for operating status

Startup of the micro annular gear pump

Voltage supply

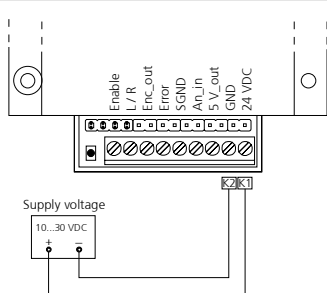

Pay attention to the correct polarity of the voltage supply, otherwise electronics will be damaged.

The length of voltage supply cable should not exceed 10 m, or the control unit could be damaged by inductance overvoltage.

Analog nominal signal

Potentiometer operating mode

connected with two jumper pins P1 and P2

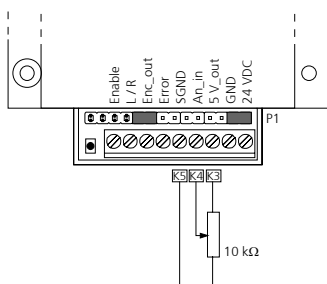

0 ... 10 V operating mode

connected with the jumper pins P3 and P4

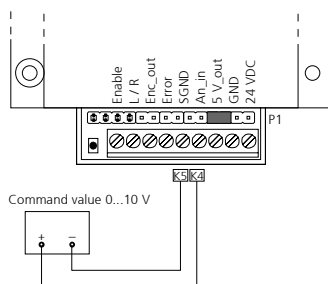

4 ... 20 mA operating mode

connected with the jumper pins P5-P6 and P7-P8

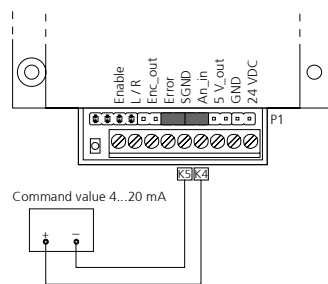

Digital inputs

Enable-Input

- not connected input or low voltage level (0 ... 0.5 V): Activated motor control
- High voltage level (4 ... 24 VDC): Deactivated motor control

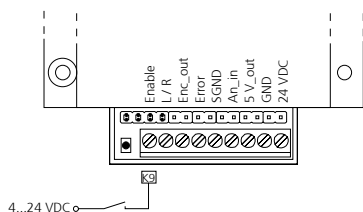

Sense of rotation input

- not connected input or low voltage level (0 ... 0.5 V): Motor turns clockwise (to the right)
- High voltage level (4 ... 24 VDC): Motor turns anti-clockwise (to the left)

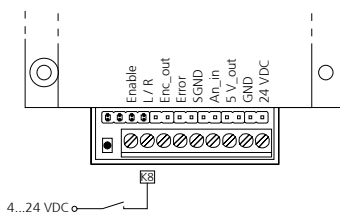

Digital output

Error output

Open collector output high voltage level (4 ... 24 VDC): no error

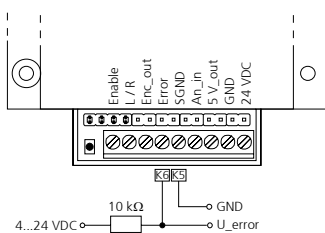

Speed signal output

Open collector output: which corresponds to channel A of the motor encoder

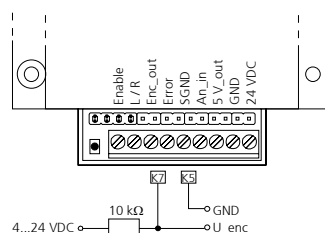

Remark:

The micro annular gear pumps mzs-2521, mzs-2921 and mzs-4622 are equipped by default with a 10-pole motor connector. For the S-KG control unit a 6-pole motor connector has been used for a more compact design.

In order to allow connection of the micro annular gear pump to the S-KG control unit, the latter is delivered with an adapter cable.

The following description has for purpose to show you how to operate the pumps equipped with a 10-pole motor connector without the adapter cable and with the control unit S-KG.

In order to replace the 10-pole motor connector with a 6-pole one, follow these steps:

- Cut off the 10-pole connector at the ribbon cable inlet with a cutter or scissors
- Place the end of the ribbon cable in the 6-pole connector, adjust its position as described in the table 21 and press the two parts of the connector tightly together. During the assembly please pay attention to the correct connector orientation. The color mark of the ribbon cable must be placed on pin 1.

6.8 Operation with the S-BL control unit (optional)

The micro annular gear pumps mzr-2521 and mzr-2921 with brushless DC motor as drive be delivered with the S-BL control unit. This programmable control unit enables to adjust speed for constant flow rates or the position of the motor for the dosage of constant amounts of liquid. On the delivered diskettes or CDs you will find a PC-program operating under Windows that enables to program such parameters as speed, acceleration and current consumption. The delivery package comprises also a null-modem cable for connection to a serial interface of a PC.

S-BL control unit			
Type of control unit		4-Q servo amplifier	
Nominal voltage	U	24	V
Power supply	U _B	12 - 30	V
Residual ripple		≤ 2 %	
Max. continuous output current	I _{continuous}	410*)	mA
Max. peak output current	I _{max}	700*)	mA
Speed range		10...6000*)	rpm
Input No. 1	input resistance	5	kΩ
Nominal analog speed	voltage range	± 10	V
Nominal digital speed	PWM signal	low 0...0.5 / high 4...30	V
	frequency range	100...2000	Hz
Input No. 2	open collector	max. U _B / 30 mA	
	no error	switched to GND	
	programmed as input	low 0...0.5 / high 3,5... U _B	V
Input No. 3	TTL - logic level	low 0...0.5 / high 3,5...30	V
	PLC - logic level	low 0...7 / high 12,5...30	V
Program memory		6,6	kBytes

*) Values limited in the control unit with corresponding software

table 24

Technical data of the S-ND control unit

The control unit permits an easy startup of the pump with:

- the possibility to connect the voltage supply to the delivered DIN socket
- the possibility to connect the voltage supply with screw clamps
- a 8-pole screw clamps connector assembly for the motor cable
- speed set with potentiometer
- analog voltage signal 0-10 V for speed control at the screw clamps
- 9-pole connection plug for the RS-232 interface
- error output with status LED, programmable also as trigger input with screw connections
- tumbler switch S1 for the connection of digital input No. 3 of the motor control unit

Startup of the micro annular gear pump with the S-BL control unit

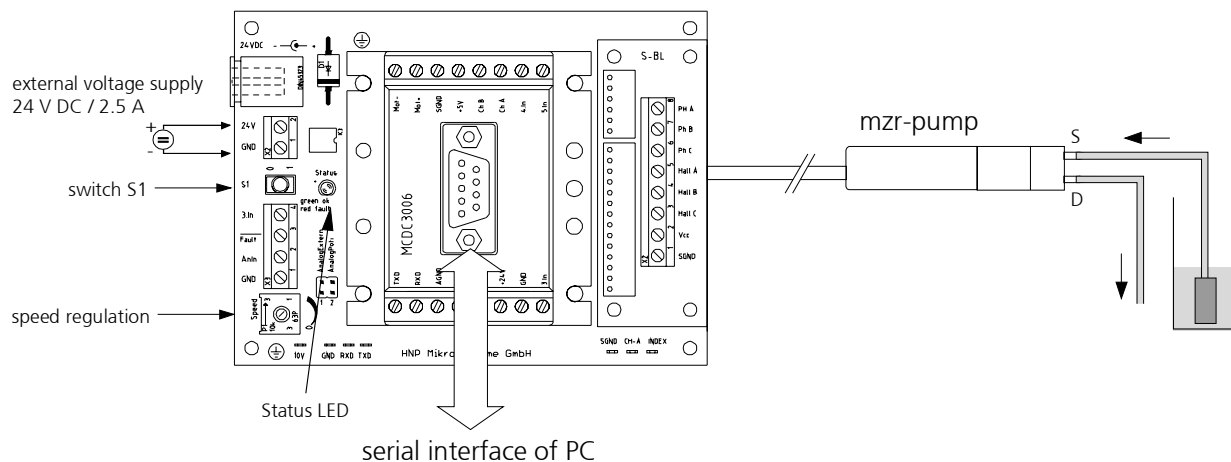

figure 27

Connection of the micro annular gear pump mzr-2521 or mzr-2921 and the S-BL control unit

1. Connect the motor cable to the 6-pole connector of the S-BL control unit. The pin configuration is indicated in table 14.
2. Connect the RS-232 port of the MCBL3006 with a free serial interface of a PC. For this purpose use the delivered 9-pole null-modem cable.
3. Put the potentiometer of the S-BL control unit to zero position by turning it clockwise to the limit stop.
4. Connect the voltage supply 24 VDC. This can be done with the integrated DIN connector or, alternatively the 2-pole screw clamp (24 V = »+«; GND = »-«). Pay attention to the correct polarity.
5. You may now install the delivered software »Motion Manager« as described in the chapter 9.



While connecting the DC voltage pay attention to the correct polarity, otherwise electronics may be damaged.

Remarks:

- It is possible to adjust speed of the micro annular gear pump with the potentiometer without the need to connect the serial interface.
- With the analog nominal value input (connection clamps »AnIN« and »GND«) it is possible to adjust speed of the pump with a standard signal 0-10°V. For this purpose it is necessary to plug the jumper on the S-BL control unit from the »AnalogPoti« to the »AnalogExtern«. The serial interface does not need to be connected.
- In case of an overcurrent error the green status LED on the S-BL control unit turns red
- The standard programs memorized in the motor control unit may be started with the tumbler switch S1. Basic sample programs are shown in the chapter 7. For more advanced programs please refer to the user manual for Motion Controller MCBL3006.

7 The startup/shutdown of a pump

7.1 Preparing for operation

After the liquid supply system had been completed, please check once again the operating conditions of the micro annular gear pump as according to the following points:

- Are the inlet and outlet tubes or hoses correctly connected?
- Is the entire liquid supply system clean - that means free of particles, foreign bodies, pollution or swarf?
- Has a filter been installed on the suction side?
- Has a sufficient amount of the right liquid been supplied?
- The pump does not run the risk of a longer dry operation?
- The entire liquid supply system has been checked for leakage?
- Is it possible to stop the pump by an emergency switch if an unexpected malfunction occurs at the first start?

7.2 Startup of the micro annular gear pump

- Switch on the voltage supply. The micro annular gear pump can now be put into operation by turning the potentiometer knob, by sending a nominal external voltage signal or with the delivered software (see chapters 8, 9).
- Start the filling in of the pump at low or middle speed (1000 - 3000 rpm).

Warning

Avoid dry operation of the pump over a longer time. The pump should be filled in before it is put into operation.

7.3 Flushing procedure after use

After each service the micro annular gear pump should be carefully flushed with a non-corrosive, filtered and particle-free flushing liquid (see table 25 / table 26). During the flushing procedure the pump should operate at about 3000 rpm and if possible against a low pressure (that can be obtained by using a restrictor, a capillary or similar). The flushing liquid must be compatible with the delivered liquid and be suitable for solving the remaining liquid rests. Depending on the application for example water, or isopropanol may be used. If you have doubts whether a liquid is suitable for this function or not, please ask the manufacturer of the liquid or HNP Mikrosysteme.

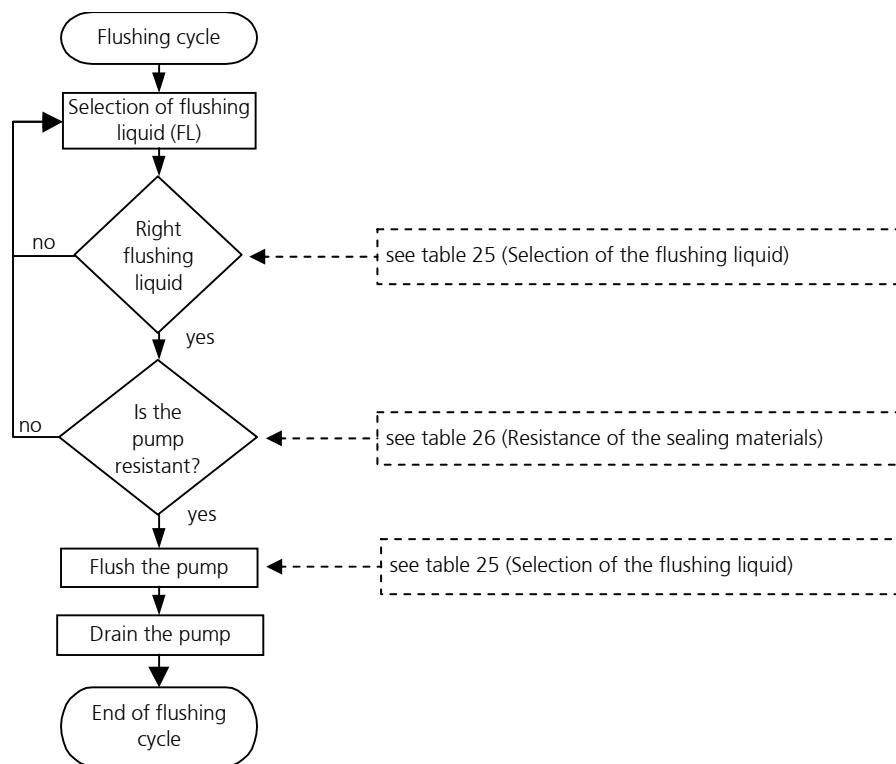

figure 28

Flushing procedure

Warning

Liquids remaining in the pump may crystallize, coagulate or lead to corrosion and as a consequence impair the work of the micro annular gear pump.

Warning

Please make sure that the pump components and particularly O-rings and sealing are resistant to the employed flushing liquid (see table 26).

Warning

The flushing liquid (solvent) and the recommended duration of the flushing procedure depend on the delivered liquid (see table 25). The indicated flushing liquids are simple recommendations and should therefore be checked by the user as to their compatibility and suitability.



Regulations concerning the use of substances dangerous to health should be followed!

	Nature of the handled liquid	Flushing cycle [min]	Suitable flushing liquid
1	Oils, fats, plastifiers	15-20	isopropanol, ethanol, acetone, benzine
2	Solvents (polar + nonpolar)	5-10	isopropanol, ethanol
3	Other organic liquids	10-15	isopropanol, ethanol
4	Refrigerating and cooling agents	15-20	isopropanol, ethanol
5	Neutral watery solutions	20-25	isopropanol, ethanol
6	Basic solutions	25-30	DI-water (deionized water)
7	Organic acids	30-40	isopropanol, ethanol
8	Weak mineral acids	25-30	DI- water
9	Strong mineral acids	35-45	DI- water
10	Strong oxidizing liquids	35-45	DI- water
11	Paints, varnishes, adhesives	50-60	Not specified - for further information please contact HNP Mikrosysteme.

table 25 Selection of the flushing liquid (solvent) and the duration of the flushing cycle depending on the delivered liquid.

Warning

Please make sure that the pump components and particularly O-rings and sealing are resistant to the employed flushing liquid (see table 26).

Flushing liquid	Shaft sealing		O-ring material		
	PTFE, graphite-reinforced	UHMWPE	FKM	EPDM	FFKM
acetone	0	0	3	0	0
benzene	0	3	1	3	0
benzyl alcohol	0	-	0	2	0
benzine	0	0	0	3	0
butanol	0	-	1	0	0
dimethyl sulfoxide (DMSO)	0	0	3	0	0
ethanol	0	0	0	0	0
isopropanol	0	0	0	0	0
methanol	0	0	2	0	0
methylethylketone (MEK)	0	0	3	1	0
oil / fine mechanics oil	0	0	0	3	0
styrene	0	-	1	3	1
toluene	0	1	2	3	0
water	0	0	0	0	0
xylene	0	1	2	3	0

Legend: 0 ... good suitability 1 ... suitability 2 ... conditional suitability 3 ... labile - ... not specified

table 26 Resistance of the sealing materials depending on the flushing liquid (solvent)

7.4 Shutdown of the micro annular gear pump

During the shutdown of the pump the following steps should be followed

- Flush the pump with a filtered and particle-free flushing liquid (solvent) (see chapter 7.3)
- After the flushing procedure decrease speed of the pump to 0 rpm
- Fill the pump with a suitable conservation liquid (see chapter 7.4.1)
- Remove the pump from the system (see chapter 7.4.2)

By proceeding as shown in the diagram (see figure 29) you may prepare the pump for a longer standstill.

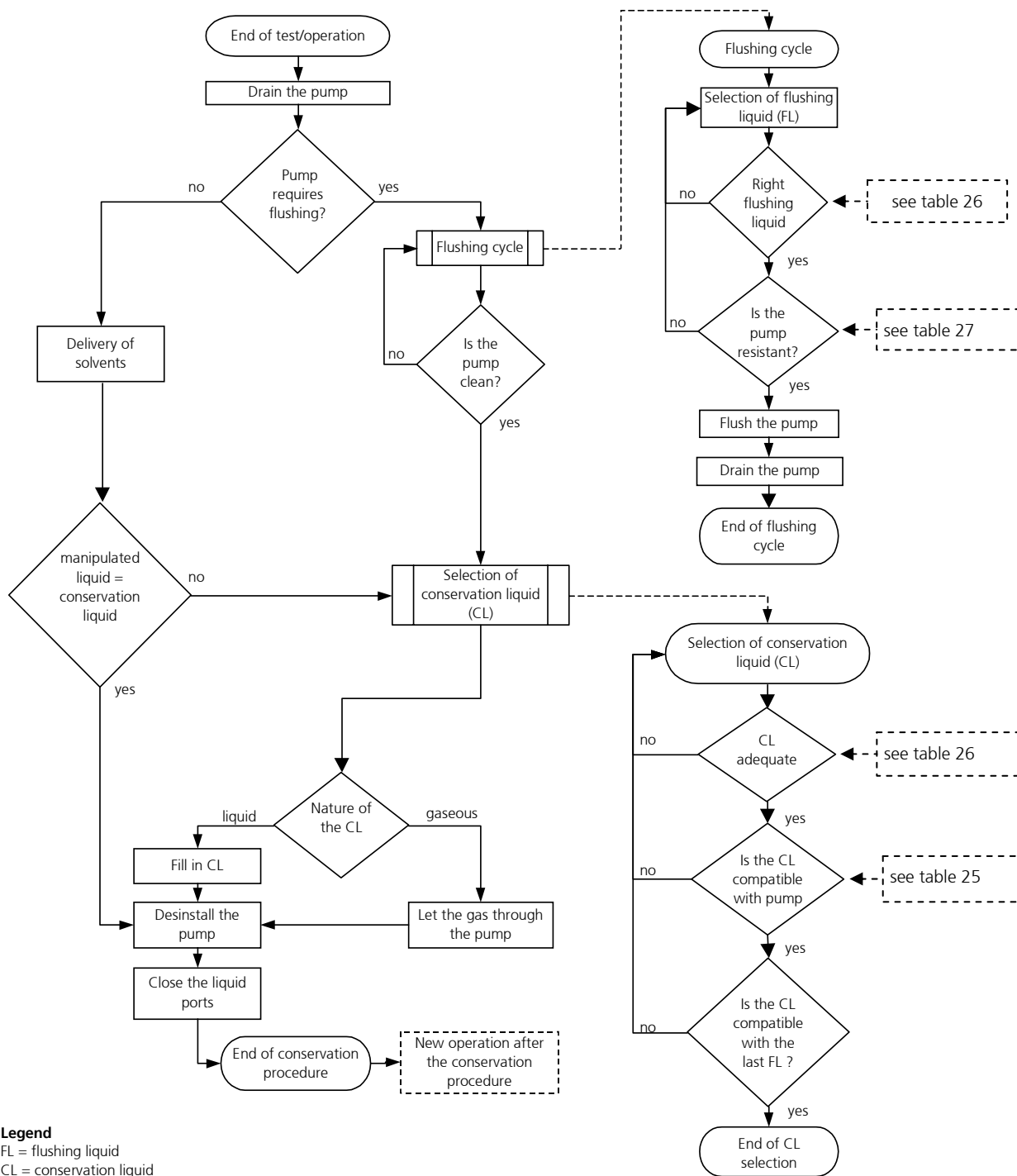

figure 29 Shutdown procedure

7.4.1 Conservation

If the micro annular gear pump operates at irregular intervals or for other reasons should be put out of operation for a longer period, it should, after service and flushing procedure (see chapter 7.3), be filled in with a suitable conservation liquid.

The conservation liquid may be selected from the table 27 depending on the duration of the standstill and the resistance of the pump to the manipulated liquid (table 26). The indicated conservation liquids are simple recommendations and should therefore be checked by the user as to their compatibility and suitability. The figure 30 presents the diagram of conservation liquid selection.

Remark: This diagram is repeated as a part of the figure 29 »Shutdown procedure«.

After the cleansing procedure the pump should be filled with a suitable conservation agent. You will find a choice of possible conservation liquids in the table 27.

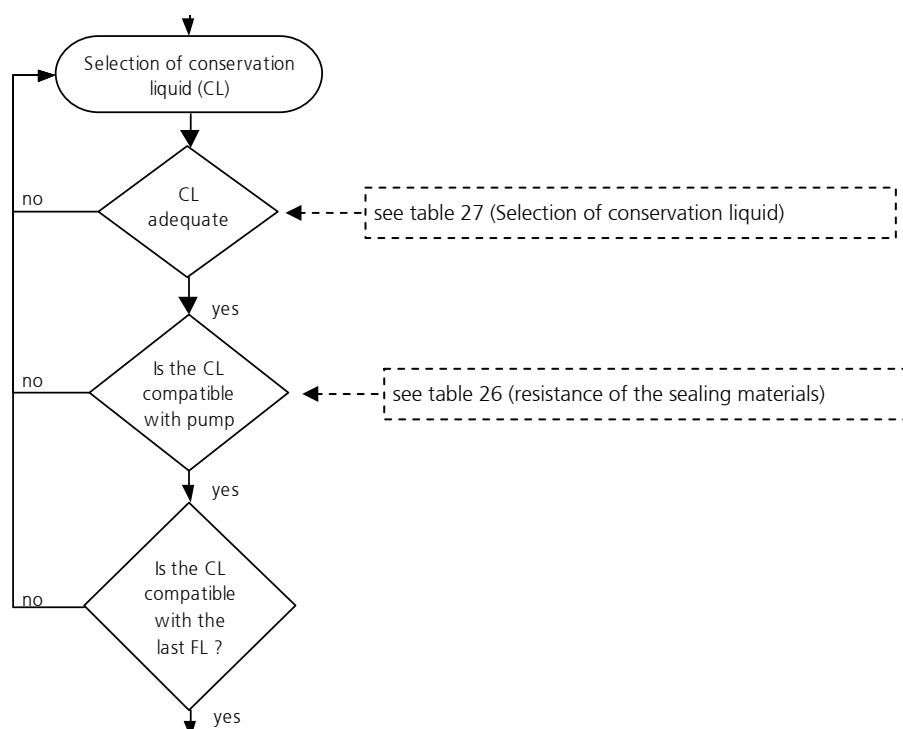

figure 30

Selection of the conservation liquid (CL)

Liquids	Solubility in water	Compatibility with the delivered liquid	Duration of storage	Breakaway torque	Toxicology	Viscosity	Description
isopropanol	+	+	o	o	o	+	solvent for organic compounds, cosmetics, essential oils, waxes and esters, antifreezers, antiseptic agents
acetone	+	+	o	o	o	+	solvent for a number of organic compounds, unlimited solubility in water, dissolves natural and synthetic resins, fats, oils and commonly used plastifiers
ethanol	+	+	o	o	o	+	solvent for organic compounds, fats, oils and resins
DI-water	+	+	-	-	+	+	solvent for many organic and mineral liquids
fine mechanics oil	-	-	+	+	+	+	cleansing and protective action (dissolves fats, tar, rubber or adhesive substances, protects against corrosion)
hydraulic oil	-	-	+	+	+	-	lubricating and preserving properties (<i>Warning: may resinate or deteriorate with time</i>)
nitrogen	-	+	+	+	o	+	is not a solvent, may leave deposits after drying out
air / compressed air		+	+	+	+	+	is not a solvent, may leave deposits after drying out

Legend: + ... good/suitable o ... satisfactory; - ... bad/inadequate

table 27

Selection of the conservation liquid

In order to prevent dust particles and foreign bodies from penetrating into the pump or the conservation liquid from leaking out, please secure the liquid input and output with the delivered protective plugs or screws.

Warning

Water or deionized water (DI-water) *should not* be used as conservation agents. These liquids germinate already after a few days and build a biofilm which can later block the pump.

7.4.2 Dismantling of the system

- Put the drive out of operation by turning down speed to 0 rpm and by switching off the voltage supply. Make sure that the procedure described in the chapter 7.3 has been completed.
- Now that the pump has been stopped you may remove it from the system.
- Protect the inlet and outlet openings of the pump with adapted protective caps or screws.

7.5 Problem shooting

If the pump does not start to operate or stops the operation abruptly, please proceed as follows:

Try to liberate the micro annular gear pump:

- by turning the potentiometer knob back and forth or by sending an analog voltage signal
- via the control software
- by pressing with a syringe a suitable flushing liquid (see table 25 and table 26) through the micro annular gear pump
- by changing the operating direction of the pump.

If these measures turn out to be ineffective, please contact the service staff of HNP Mikrosysteme (see chapter 15) and send the pump back to the manufacturer for inspection.

Warning

You should under no condition try to dismantle the pump by yourself. This may cause damage to the pump components and consequently annul your warranty claims.

7.6 Return of the micro annular gear pump to the manufacturer

For the return of a micro annular gear pump and components that have already been employed, please follow the instructions:

- drain any remaining rests of the delivered liquid from the pump
- flush the pump with an adapted solvent
- remove the filter elements from integrated or loosely delivered filters
- protect all openings against dust with the delivered protective plugs or screws
- return the pump in its original packing

The service personnel which carries out the repair should be informed about the condition of the used micro annular gear pump. This is done by means of the "Declaration of media in contact with the micro annular gear pump and components" (see chapter 18). This form may also be downloaded from the web site www.hnp-mikrosysteme.de/download.



The "Declaration of media in contact with the micro annular gear pump and components" must imperatively be filled in. The nature of liquid which entered into contact with the micro annular gear pump and the components must be specified.

In case of non-compliance, the sender will be liable for any resulting injure to persons or any object damage.

8 Software »mzr-pump control«

Install the delivered software »mzr-pump control« from both diskettes or CDs by starting the program »Setup« on the diskette »Disk 1« or CD. The delivered software is compatible with Windows 95®, Windows 98®, Windows NT, Windows 2000® and Windows XP®.

The program enables to coordinate metering or continuous delivery tasks. The operating parameters of the micro annular gear pump are set with the included user interface.

If the diskettes »mzr-pump control« are not available because you have received for example the »Motion Manager« software instead, you may download this software from the web site www.hnp-mikrosysteme.de/downloads.htm. The updated version is always available in English and German.

After a successful installation the program »mzr-pump control« can be found in the start menu under »Programs - HNP Mikrosysteme«. After the program had been initiated, data such as the pump type »mzr-2521« and »mzr-2921«, the encoder resolution and the gear reduction should be set.

The »Dosage« operating mode (see figure 31) enables to set constant volumes in units such as ml, mg or rpm as well as pauses for a fixed number of sequences or for continuous operation. Each metering procedure will be configured as according to speed profile which is set for such values as »Max. velocity« and the »Acceleration«. The maximal allowable speed values extend from 1 to 6000 rpm and the acceleration values from 1 to 2000 rotation/s².

A dosage task can be initiated with the »Start« button or by pressing the enter key. The task may be stopped either with the »Stop« button or by pressing once again the enter key.

In the »Continuous flow« operating mode (see figure 32) continuous flow rates in units such as ml/min, g/min and rpm may be set. The operation of the micro annular gear pump for the indicated »Duration« value may be initiated with the »Start« button or by pressing the enter key. Checking of the »endless« box will put the pump to continuous operation. Pressing on the »Stop« button or on the enter key once again will stop the delivery. If you check the »Potentiometer« box, speed may be set by turning the potentiometer knob in the front of the control module or on the control unit.

The input of the »Fluid density« enables to convert units of weight to the given volumes or flow rates expressed in volume units.

Remark: if you are only working with volumes, the indication of liquid density will not be necessary and the standard value »1« can be left.

The »Calibration factor« enables to find the relation between the actually delivered quantities or flow rates (= actual value) and the set up quantities or flow rates (=nominal value). The calibration factor is specific to every pump and each application case and therefore should be determined by the user as

according to the volume or weight of the delivered liquid. The calibration factor may be calculated according to the following formula:

$$\text{Calibration factor} = \frac{\text{Desired quantity}}{\text{Actual quantity}} = \frac{\text{Desired delivery value}}{\text{Actual delivery value}}$$

In practice, due to the high precision of the system the value of the calibration factor will only slightly exceed 1.

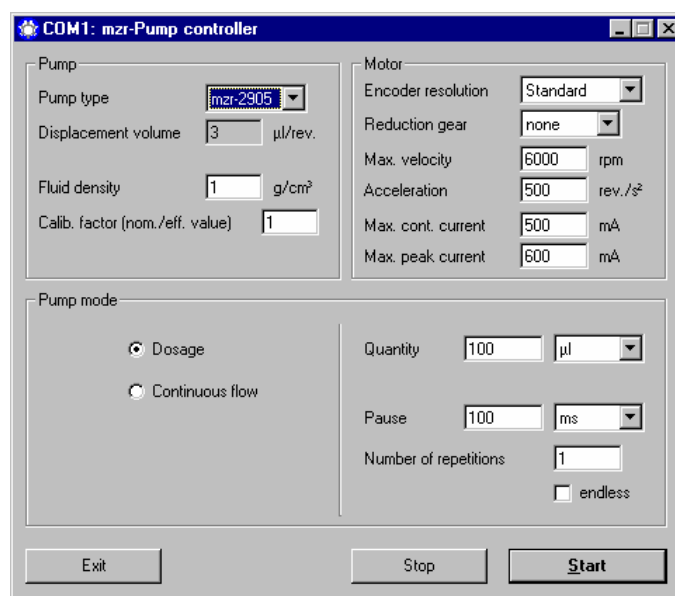

figure 31

Setup window in the »Dosage« operating mode

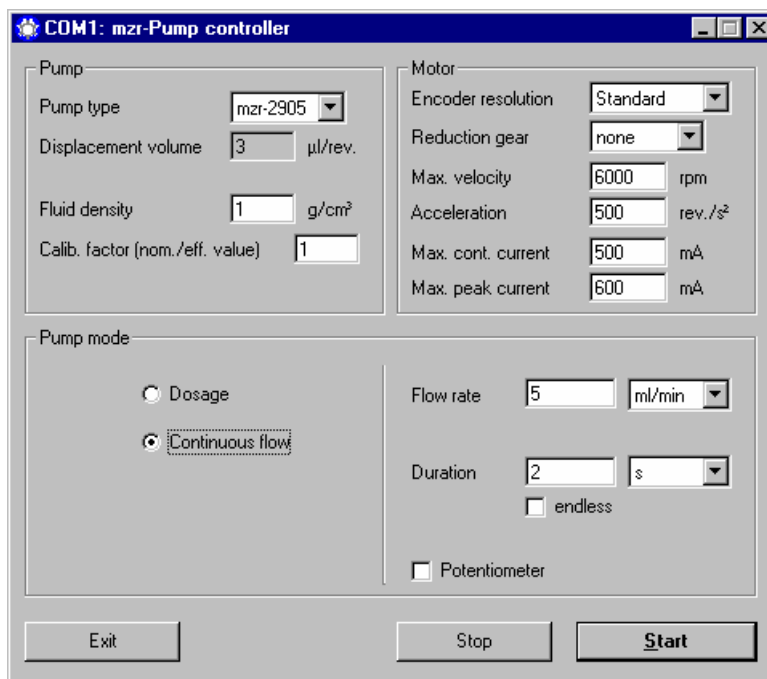

figure 32

Setup window in the »Continuous flow« operating mode

9 »Motion Manager« software (optional)

The »Motion Manager« software enables operation and configuration of the drive and offers a possibility of an online graphic analysis of the operating data. The software is delivered on two diskettes. The program may be installed on a PC running under Windows 95®, Windows 98®, Windows NT®, Windows 2000® or Windows XP® operating systems.

Install the software »Motion Manager« by starting the program »Setup« from the diskette »disk 1«.

If the »Motion Manager« diskettes are not available, and you have received for example the »mzr-pump control« software, you may still download this program from the web site www.hnp-mikrosysteme.de/downloads.htm or the web site www.faulhaber-group.com (menu technical library - software download). Here, the latest version is always available in English and German.

After the installation the »Motion Manager« program may be loaded from the »Faulhaber Motors« folder from the Windows start menu.

In order to program the drive, the micro annular gear pump should be put into operation. The drive should be connected to the PC with the delivered null-modem cable.

9.1 Direct drive control

The »Motion Manager« software enables to send the input commands directly to the drive. This allows execution of movement commands and modification of the drive parameters. (see figure 33)

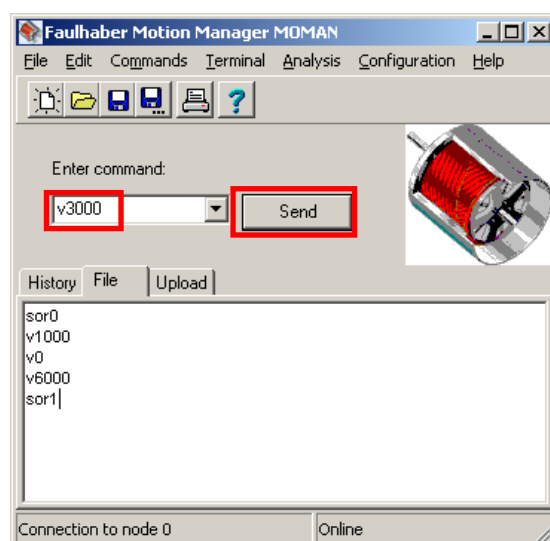

figure 33

Motion Manager software for direct control of the drive

The commands are entered in the field »Enter command:«. The button »Send« will send the command to the drive for execution (see figure 33). The commands may be given alternatively in capital or lowercase letters. Excess space characters will be ignored by the drive.

An example for continuous delivery

Command	Description
SOR0	Set the nominal speed via the RS-232 interface
V1000	Operate the pump at 1000 rpm (for the mzr-2521 with a displacement volume of 1.5 µl a flow rate of 1.5 ml/min is obtained; for the mzr-2921 a flow rate of 3 ml/min)
V0	Pump at rest (speed 0 rpm)
V6000	Operate the pump at 6000 rpm (Flow rate: mzr-2521 = 9 ml/min; mzr-2921 = 18 ml/min)
SOR1	Analog input operating mode: Set the nominal speed with potentiometer or by connecting a voltage signal to the analog input

An example for discrete dosage

Command	Description
SOR0	Set the nominal speed via the RS-232 interface
LR320	Load a relative position of 320 to the control unit 320 = 5 rotation cycles, displaced volume mzr-2521 ≈ 7.5 µl; mzr-2921 ≈ 15 µl (Remark: 64 steps = 1 rotation)
M	Execute the task / start positioning
LR640	Load a relative position of 640 to the control unit (640 = 10 rotation cycles, displaced volume mzr-2521 ≈ 15 µl; mzr-2921 ≈ 30 µl)
M	Execute the task / start positioning
SOR1	Analog input operating mode: Set the nominal speed with potentiometer or by connecting a voltage signal to the analog input

Because of the 4-edge evaluation of the encoder signal by the control unit S-ND a quadruple number of counts per turn must always be given. In case gear box module is used, the respective gear reduction must be taken into

consideration. For detailed information as to the use of Motion Manager, please read the program online help.

9.2 Programming of the control unit

The S-ND control unit of the micro annular gear pump may be adapted by the user to a specific application by means of an easy programming language. The program files are available in the ASCII code and have by default the »mcl« extension which stands for "motion controller language". Various parameters of the drive such as the maximal speed, the acceleration, the number of rotations to be executed, the allowable current load and the parameters of the PI-controller may be programmed. Furthermore, it is possible to program short movement sequences which will be saved in the independent memory of the drive and then autonomously executed.

A diskette with mcl-programs is included in the delivery and may be saved in the control unit.

9.3 Transfer of a mcl-file to the drive

The existing mcl-files may be downloaded to the editor window by selecting File – Open (see figure 34).

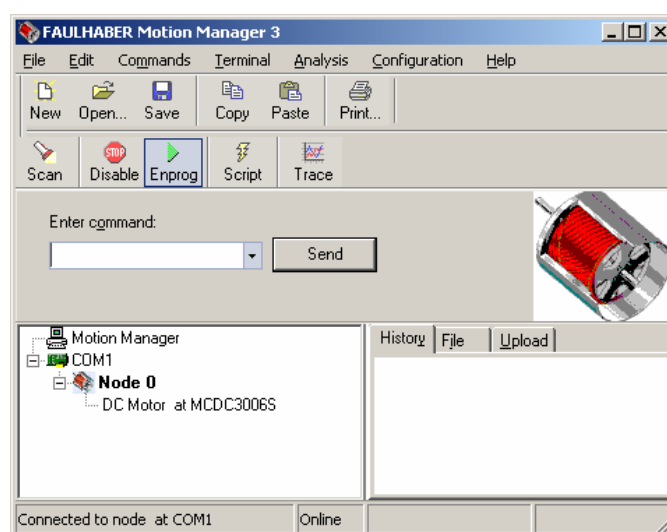

figure 34

Menu file- open

The required mcl file may be selected and loaded from the file selection window (see figure 35).

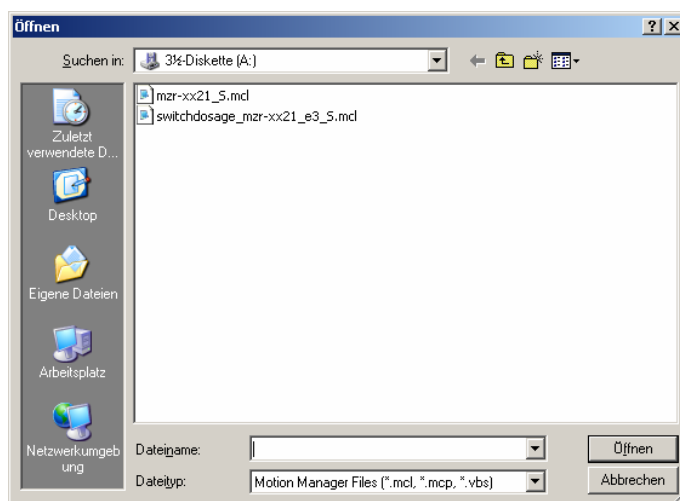

figure 35

File selection window

The mcl-file is transferred to the drive by selecting *Terminal - Transfer Configuration file* from the menu (see figure 36).

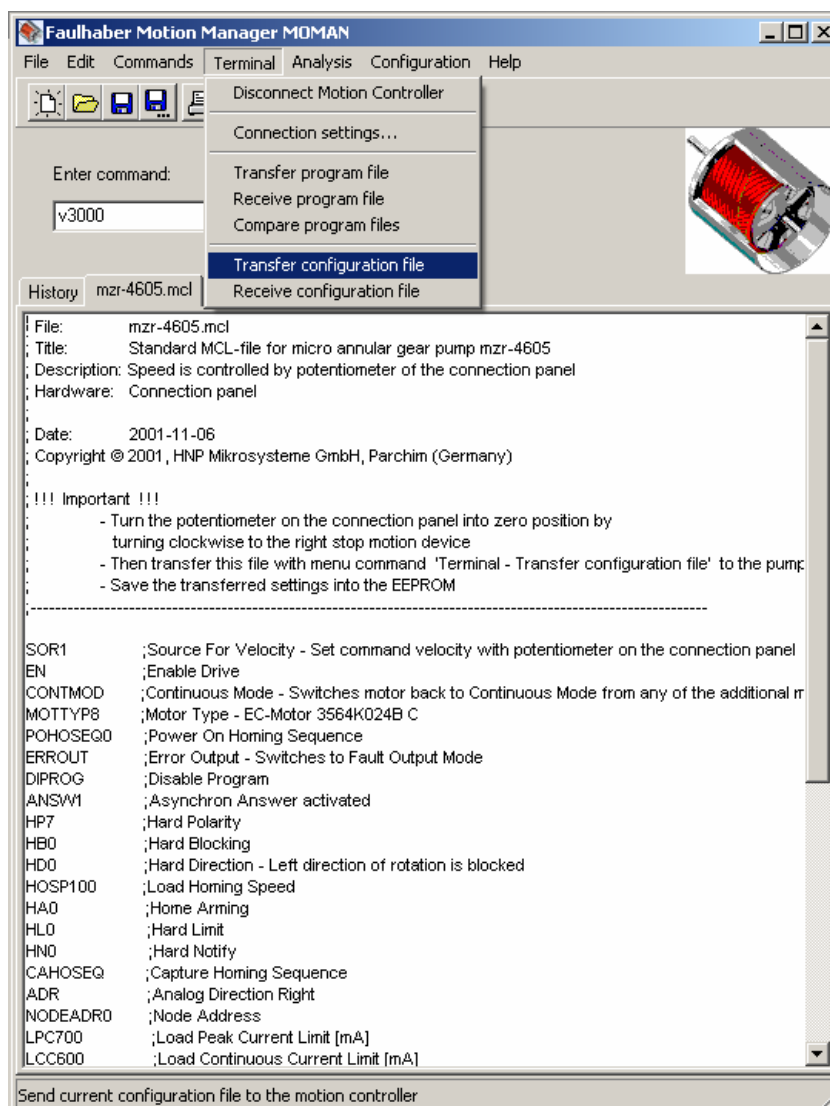

figure 36 Transfer of a mcl-file as a parameter data

When a window appears with the enquiry if the mcl files should be transferred to the »Motion-Controller«, answer by clicking on the »Yes« button.

In order to save the configuration and the programmed operation files in the EEPROM, please confirm the dialogue window with »OK« (see figure 37). With this confirmation the program will be saved in the memory with a resident status and will be available for future operation.

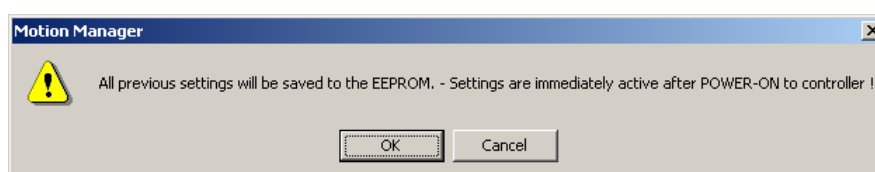

figure 37 Storage confirmation

A standard program mzs-xx21_S.mcl and a sample program switchdosage_mzs-xx21_e3_S.mcl may optionally be delivered.

The standard program mzs-xx21_S.mcl (see Listing 1) is installed by default at the delivery of the micro annular gear pumps mzs-2521 and mzs-2921.

In this case the drive has the following parameter configuration:

- speed set with potentiometer (command SOR1)
- drive activation when the power supply is switched on (command EN)
- continuous operation mode of the micro annular gear pump (command CONTMOD)
- maximal speed 6000 rpm (command SP6000)
- max. peak current of the drive 400 mA (command LPC400)
- max. continuous current of the drive 220 mA (command LCC220)
- motor acceleration 500 rotations/s² (command AC500)
- fault-pin configured as error output (command ERROUT)
- activation of automatic answering (command ANSW1)
- the program memory is empty

```

; File:          mzs-xx21_S.mcl
; Title:         Standard mcl-file for micro annular gear pump mzs-2521/mzs-2921
; Description:   Speed is controlled by potentiometer of the controller
; Hardware:     Motor Maxon RE 13, Steuerung MCDC3006S on motion controller S-ND
;
; Date:         2007-08-20
; Copyright © 2007, HNP Mikrosysteme GmbH, Parchim (Germany)
;
; !!! Important !!!
;   - Turn the potentiometer on the connection panel into zero position by
;     turning clockwise to the right stop motion device
;   - Then transfer this file with menu command 'Terminal - Transfer configuration file' to the pump
;   - Save the transferred settings into the EEPROM
;
;-----
; Configuration
;-----
SOR1           ;Source For Velocity over Potentiometer
CONTMOD       ;Continuous Mode
KN738        ;Speed constant
RM21500      ;Motor resistance
APL0         ;Position Limits deactivated
MOTTP0       ;Motortype
POHOSEQ0     ;Power On Homing Sequence
ERROUT       ;Error Output
HP7          ;Hard Polarity
HB0          ;Hard Blocking
HD0          ;Hard Direction
HOSP100     ;Load Homing Speed
SHA0         ;Home Arming deactivated
SHL0        ;Hard Limit deactivated
SHN0        ;Hard Notify deactivated
CAHOSEQ     ;Capture Homing Sequence deactivated
ADR          ;Analog Direction Right
LPC400       ;Load Peak Current Limit [mA]
LCC220       ;Load Continius Current Limit [mA]
AC500        ;Load Command Acceleration [U/s²]
DEC500       ;Load Command Deceleration [U/s²]
POR4         ;Load Velosity Proportional Term
I20          ;Load Velocity Integral Term
PP20         ;Load Position Proportional Term
PD6          ;Load Position D-Term
CI16         ;Load Current Intergral Term

```

```

SP6000 ;Load Command Velocity [U/min]
MV0 ;Minimum Velocity
MAV50 ;Minimum Analog Voltage
LL600000000 ;Load Position Range Limits
LL-600000000 ;Load Position Range Limits
LPN10 ;Load Puls Number
STW1 ;Load Step Width
STN16 ;Load Step Number
ENCRES64 ;Load Encoder Resolution
CORRIDOR10 ;Load Corridor
DEV50 ;Load Deviation
DCE200 ;Delayed Current Error [1/100 Sek.]
SIN0 ;Sinus Commutation
SETPLC ;Set PLC Inputs
EN ;Enable Drive
COMPATIBLE0 ;Deactivated Compatible Mode
SR18 ;Load Sampling Rate [ms/10]
NET0 ;Set network Mode
NE0 ;Notify Error
NODEADR0 ;Define Node Address
ANSW1 ;Asynchron Answer activated
V0 ;Select Velocity Mode

;-----
; Program
;-----
PROGSEQ ;write and save an empty program sequence (clear program memory)
END

```

Listing 1

file mzr-xx21_S.mcl

The switchdosage_mzs-xx21_e3_S.mcl file (see Listing 2) is a sample program for discrete dosage with the micro annular gear pump.

The dosage task is started with the switch S1 located between the connection clamps »24V« and »3.In« on the connection board. Buttons, shutters or no-load contacts of a programmable controller with interchangeable memory (PLC) may be used as interruptors.

The drive is configured as according to the following parameters:

- Execution of 10 rotation cycles (command LR640) (640 = 10 rotation cycles, displacement volume mzs-2521 \approx 15 μ l; mzs-2921 \approx 30 μ l)
- Start the dosage task with the integrated switch (command REFIN)

```

; file:          switchdosage_mzs-xx21_e3_S.mcl
; Title:         Dosage triggered with switch for mzs-2521 / mzs-2921
; Description:   A fluid quantity which is defined by relative target position of the motor will be triggered
with switch
; Hardware:     Motor Maxon RE 13, Steuerung MCDC3006S on S-ND
;
;
; Date:         2007-08-20
; Copyright © 2006, HNP Mikrosysteme GmbH, Parchim (Germany)
;
; !!! Important !!!
;              - Turn the potentiometer on the connection panel into zero position by
;              turning clockwise to the right stop motion device
;              - Then transfer this file with menu command 'Terminal - Transfer configuration file' to the
pump
;              - Save the transferred settings into the EEPROM
;
;-----
; Program sequence
;-----
PROGSEQ
A1          ;Label 1 (program start)
HP4        ;Rising edge active and logic level to High for input No. 3
A2          ;Label 2
JPT2       ;Jump to label 2 if logic level of input No. 3 is low

HP0        ;Falling edge active and logic level to Low for input No. 3
A3          ;Label 3
JPT3       ;Jump to label 3 if logic level of input No. 3 is high

LR640      ;Load relative target position (64 = 1 rev.) <+++++ Please edit the target
position value !
NP         ;Notify Position (wait after "M" until target position is reached)
M          ;Move to target position
HO         ;Home arming

JMP1       ;Jump to the beginning
END

;-----
; Configuration
;-----
SOR0       ;Source For Velocity over RS-232
EN         ;Enable Drive
CONTMOD    ;Continuous Mode
COMPATIBLE0;Deactivated Compatible Mode
NET0       ;Set network Mode
NE0        ;Notify Error
MOTYP0     ;Motortype
KN738      ;Speed constant
RM21500    ;Motor resistance
POHOSEQ0   ;Power On Homing Sequence
ERROUT     ;Error Output

```

DIPROG	;Disable Program
ANSW1	;Asynchron Answer activated
HP7	;Hard Polarity
HB0	;Hard Blocking
HD0	;Hard Direction
HOSP100	;Load Homing Speed
SHA0	;Home Arming deactivated
SHL0	;Hard Limit deactivated
SHN0	;Hard Notify deactivated
CAHOSEQ	;Capture Homing Sequence
ADR	;Analog Direction Right
NODEADR0	;Define Node Address
LPC400	;Load Peak Current Limit [mA]
LCC220	;Load Continius Current Limit [mA]
AC1000	;Load Command Acceleration [U/s ²]
DEC1000	;Load Command Deceleration [U/s ²]
POR1	;Load Velocity Proportional Term
I20	;Load Velocity Integral Term
PP140	;Load Position Proportional Term
PD6	;Load Position D-Term
CI16	;Load Current Intergral Term
SR18	;Load Sampling Rate [ms/10]
CORRIDOR100	;Load Corridor
SP6000	;Load Command Velocity [U/min]
SIN0	;Sinus Commutation
MV0	;Minimum Velocity
MAV25	;Minimum Analog Voltage
SETPLC	;Set PLC Inputs
LL600000000	;Load Position Range Limits
LL-600000000	;Load Position Range Limits
LPN10	;Load Puls Number
STW1	;Load Step Width
STN16	;Load Step Number
ENCRES64	;Load Encoder Resolution
V0	;Select Velocity Mode
LR0	;Load relative target position
M	;Move to target position
ENPROG	;Enable Program - start the program sequence immediately after power-on

Listing 2

file switchdosage_mzr-xx21_e3_S.mcl

10 Accessories for microfluidic systems

The accessory range for the liquid delivery systems of HNP Mikrosysteme comprises complementary equipment such as supplementary modules, hoses, tubing, fluid connection fittings, filters and non-return valves that are best adapted to your micro annular gear pump. We will eagerly share our long date experience as far as component selection is concerned.

11 Non-liability clause

HNP Mikrosysteme GmbH shall not be liable for damages resulting from the non-respect of instructions comprised in this operating manual.

It remains at the responsibility of the user to conform to all laws, rules and regulations in force. This applies above all to the handling of aggressive, poisonous, corrosive and other dangerous liquids as well as to the electromagnetic compatibility (EMC).

12 Electromagnetic compatibility (EMC)

The control units S-ND and S-KG have been checked according to the Electromagnetic Compatibility Directive 89/336/EEC.

In order to help you comply with the EMC-protection measures restrictions concerning the S-ND control unit have been listed in the enclosed manual "Motion Controller for DC-Motors MCDC3006".

For the control unit S-KG no further conditions must be fulfilled in order to comply with the EMC-protection requirements.

13 Problem shooting

Disturbance	Cause	Solution
1 The pump does not start operation.	No power supply	Check the power supply.
2 The pump does not deliver any liquid.	No liquid in the primary tank.	Fill the recipient/tank with liquid.
	Presence of air or gas in the pump	The pump cannot run dry against the system pressure. Fill in the pump at no pressure or at reduced system pressure.
	Malfunction of the liquid supply system (such as in the delivery tube or hose, the needle or external non-return valve)	Check the components for possible disturbances to be eliminated. Cleanse the accessories if needed.
	Failure of the electric installation.	Check the electric installation for the correct cable configuration, loose contacts, etc.
	The pump did not receive the start signal or start conditions are not fulfilled.	Check if the start conditions have been fulfilled start signals (PLC, start input) and the programming.
	Motor fault: Status LED of the control unit S-ND turns red.	Check the error status of the S-ND control unit with the Motion Manager software. Read the operating manual for the motor control unit.
3 The pump does not start to operate.	The pump does not take in the liquid.	The tubing on the suction side is too long or has a too small internal diameter (a too low NPSHA value).
		The tubing or the fluid connection on the suction side are not tight. Please check the intake connection and the tubing.
		Air bubbles in the system (tubes, valves, ...)
		If the viscosity of the liquid is too high, apply pressure on the suction side.
		Check the pressure exerted on the primary liquid tank.
		An external non-return valve does not open. Check the non-return valves.
		Submit the non-return valve to a higher pressure, so that the pump may fill in.
4 The motor turns, but the pump does not operate.	No liquid in the pump	Fill the pump with liquid.
	Air bubbles in the liquid supply system (tubing, valves, ...)	Fill the pump and the liquid supply system with liquid.
	The non-return valve does not open.	Rinse the non-return valve.
	Blocked delivery tubing or needle	Cleanse, flush or exchange the delivery tubing or dosage needle.
	The coupling between the motor and the pump is out of position.	Return the pump to the manufacturer.
	The pump shaft is broken.	Return the pump to the manufacturer.
5 The pump is filled with liquid, but does not pump it.	Error indicator (the status LED has turned red and the motor control has set the error output.)	Check the motor error status with the Motion Manager software (command GFS). Try to liberate the pump by making it operate in a reverse direction for 1 s with - 1000 rpm. Adapt the motor current of the control. Contact the manufacturer of the pump.
	Presence of particles in the delivered liquid or blockage of the pump	Check the motor error status with the Motion Manager software. Try to liberate the pump by making it operate

Disturbance	Cause	Solution
		in a reverse direction for 1 s with - 1000 rpm.
		Flush the pump with a syringe.
		Return the pump to the manufacturer for cleansing. Use a filter, flush the liquid delivery system.
	The non-return valve does not open.	Rinse the non-return valve.
	Blockage of the delivery tubing or the needle	Cleanse, flush or exchange the delivery tubing or the needle.
	Air bubbles in the liquid delivery system (tubing, valves)	Fill in the pump and the liquid delivery system with liquid.
6 Dosage volume does not correspond to the desired values.	Air bubbles in the liquid delivery system (tubing, valves ,...) and the pump	Vent the liquid delivery system and check for untight fluid connections.
	Pump shows cavitation.	Too long or too narrow intake tubing. Shorten the intake tubing or change the position of the pump.
	Polluted or too small filter	Change the filter to a new or bigger one.
	The non-return valve does not open.	Rinse the non-return valve.
7 Speed of the pump cannot be adjusted.	Defective electric installation	Check the electric installation for correct cable configuration and loose contacts.
	Defective drive control	Return the drive control unit to the manufacturer.
	Encoder cable disconnected	The motor works at high speed. Check the installation, return the pump to the manufacturer for checkup.
8 Liquid drops from the dosing needle.	The non-return valve does not close.	Rinse the non-return valve.
	Too high pressure on the primary liquid tank	Stop the delivery of compressed air on the primary liquid tank.
	The liquid tank is at a higher level than the dosing needle.	Place the liquid tank at the same or slightly lower level as the pump.
9 Liquid leaks out of the sealing module.	Too high pressure on the sealing liquid supply cartridge or defective sealing	Stop pressurizing the sealing liquid supply cartridge. If needed return the pump to the manufacturer.
10 Dosage volume decreases with time.	Polluted filter	Exchange the filter.
	Deposits in the pump	Flush the pump or return it to the manufacturer for dismantling and cleaning.
	The pump is worn after a long operating period or after use with abrasive liquids.	New definition of the calibration factor of the pump, by modifying the pump characteristics graph necessary.
11 Leakage from the pump	The sealing does not function correctly.	Return the pump to the manufacturer.
12 Leakage from the coupling assembly	Defective shaft seal	Return the pump to the manufacturer in order to change the shaft sealing.
13 Leakage from the fluid connections	Untight locking rings	Exchange or tighten the fluid connections, exchange the fluid connection.
14 Air bubbles on the delivery side.	Loose fluid connections (particularly on the induction (suction) side)	Check and tighten the fluid connections.
	The shaft seal is untight or worn.	Return the pump to the manufacturer.
15 The error status of the pump cannot be retrieved.	No connection with the pump	Check the supplied voltage.
		Check the connection of the interface with the null-modem cable. Replace the cable if needed.
	The motor control unit does not respond.	Turn off the voltage supply for a short time, then turn it on again. Start the pump automatically with the integrated control unit.

Disturbance	Cause	Solution
16 Minimal leakage during standstill	No error, cause relative to the operating principle	Use a non-return valve. Place the liquid tank at the same or slightly lower level as the pump.
17 Excess temperature	The surface of the pump is hot.	Clean the surface of the pump, rinse the pump.
	The pump operates with difficulty.	The pump should be flushed.
	Particles in the delivered liquid or deposits in the pump	The operation of the pump should immediately be stopped! Return the pump to the manufacturer for cleansing.
	Noise of beveling	The operation of the pump should immediately be stopped! Return the pump to the manufacturer for cleansing and repair.
18 The pump is noisy.	The motor surface or the motor interior are too hot.	High temperature indicator in the drive is on. The motor has been shut down by the thermistor. Return the pump to the manufacturer.
	Wear out of the pump or defective components.	Do not continue to operate the pump, return it to the manufacturer for maintenance.
19 Overcurrent	Particles in the delivered liquid	Rinse the pump.
	The pump operates with difficulty.	Dosing needle is damaged. Needle should be cleansed, flushed or exchanged. Tubing on the delivery side, dosing needle or the non-return valve are blocked. Cleanse, flush or exchange the components.
	Deposits inside the pump.	Flush the pump. If necessary return the pump to the manufacturer.
20 Undervoltage	Voltage supply < 12 VDC	Check the power supply 24 VDC
21 Overvoltage	Voltage supply > 28 VDC	Check the power supply 24 VDC. The drive control unit may be damaged. Return the pump to the manufacturer.

table 28

Problem shooting



If a disturbance that has not been mentioned in the above list, or that makes the use of the micro annular gear pump unsafe appears, please stop the operation of the pump without delay and contact HNP Mikrosysteme (see chapter 15). If needed return the pump to the manufacturer for checkup.

14 Service, maintenance and warranty

Maintenance of the micro annular gear pump should be carried out depending on the delivered liquid:

- *for lubricating liquids* after 6000 working hours, but not later than 15 months after the initial operation
- *for non-lubricating liquids, crystallizing liquids or liquids containing particles*, after 4000 working hours but not later than 12 months after the initial operation. If during the first inspection no substantial wearout of the pump is observed, the following inspection under the same working conditions should be performed after 6000 working hours, yet not later than 15 months following to the last inspection.

If during the first inspection the pump shows a particularly strong wearout, the maintenance intervals should be readapted to the changing operating parameters.

In order to prevent a strong wearout of the pump, the pump should be shut down properly after every application as described in the chapter 7.3. A supplementary flushing procedure with a neutral flushing liquid (see chapter 7.3) also slows down the wearout process of the pump.



It is not allowed to open or dismantle the micro annular gear pumps. The warranty extinguishes with the expiry of the legal warranty period or with the opening of the pump. Furthermore HNP Mikrosysteme cannot give any warranty of exchange for parts whose damage result from incorrect use.



For service and maintenance please return your micro annular gear pump to HNP Mikrosysteme. You will find the address on the cover of the present operating manual.



The declaration of media (liquids) having had contact with the micro annular gear pump and components must imperatively be completed. The nature of media (liquids) must be specified. In case of non-compliance the sender will be liable for any resulting injury to persons or any object damage.



Sealing elements, rotors and shaft are parts that undergo wear and will be replaced by HNP Mikrosysteme GmbH during maintenance depending on their degree of wear.

15 Contact person

Development and application assistance, service and accessories

Mr. Sven Reimann
Phone +49| (0) 3871|451-349

Service and maintenance

Mr. Steffen Edler
Phone +49| (0) 3871|451-307

Drive and control technology

Mr. Lutz Nowotka
Phone +49| (0) 3871|451-346

16 Legal information

Marks

Microsoft®, Windows® are registered trademarks of Microsoft Corporation in the USA and in other countries.

mzr® is a registered trademark of HNP Mikrosysteme GmbH.

The other product names or descriptions not mentioned above are possibly registered trademarks of related companies.

Patents

Micro annular gear pumps (and housings) are protected by assigned patents: DE 198 43 161 C2, EP 1115979 B1, US 6,520,757 B1, EP 852674 B1, US 6,179,596 B1, EP 1354135. Patents pending: DE 101 46 793, US 10,466,792, DE 10 2004 052 866. In the US, Europe and Japan additional patents are pending.

17 Safety information for the return of already employed micro annular gear pumps and components

17.1 General information

The operator carries the responsibility for health and safety of his/her employees. The responsibility extends also to employees not belonging to the company that have a direct contact with the micro annular gear pump and its components during repair or maintenance works. The nature of media (liquids) coming into contact with the micro annular gear pump and its components must be specified in the corresponding declaration form.

17.2 Declaration of media in contact with the micro annular gear pump

The staff performing the repair or maintenance works must be informed about the condition of the micro annular gear pump before starting any work on the device. The "Declaration of media in contact with the micro annular gear pump" should be filled in for this purpose.

The declaration should be sent directly to the supplier or to the company designated by the supplier. A second copy of the declaration must be attached to the shipment documents.

17.3 Shipment

The following instructions should be observed for the shipment of the micro annular gear pump.

- drain the pump from any remaining liquid
- flush the pump with an adapted flushing liquid
- remove the filter elements from the integrated or loosely delivered filters
- all the openings should be air-tight plugged
- return the pump in the original packing

18 Declaration of media in contact with the micro annular gear pump and its components

Type of the device

Pump type/serial number/article:

Operating hours/running time:

Bill of delivery number and the delivery date:

Reason of the return:

.....
.....
.....

Contact with media (liquids)

The micro annular gear pump has entered into contact with:

.....

and has been cleansed with:

.....

The safety specification of the liquid has been attached (Yes / No):.....
or is available on the following web site: www.....

If the pump having had contact with dangerous substances could not be properly cleansed prior to the shipment, we reserve the right to entrust a specialized company with the cleansing of the device. The return of the pump in the original packing is purposive. This measure is necessary in order to protect the employees and the delivery staff.

Nature of the delivered liquid:

- | | | |
|---|--|--|
| <input type="checkbox"/> explosive | <input type="checkbox"/> oxidizing | <input type="checkbox"/> susceptible to moisture |
| <input type="checkbox"/> toxic (toxic byproducts) | <input type="checkbox"/> radioactive | <input type="checkbox"/> pH-value: |
| <input type="checkbox"/> carcinogenic | <input type="checkbox"/> microbiological | <input type="checkbox"/> other: |
| <input type="checkbox"/> caustic | <input type="checkbox"/> corrosive | |

Declaration

I/we certify herewith that the stated information is exhaustive and correct. The micro annular gear pump and corresponding liquid supply components are shipped in conformity with the applicable regulations.

Company/Institute:

Street: Zip code, location:

Telephone: Fax:

Contact person (in printed characters):

Date: Company stamp:

Obligatory signature:

19 Appendix

- Layouts
- Operating manual for the S-KD control unit
- Operating manual for the S-KG control unit (optional)
- Operating manual for the S-BL control unit (optional)

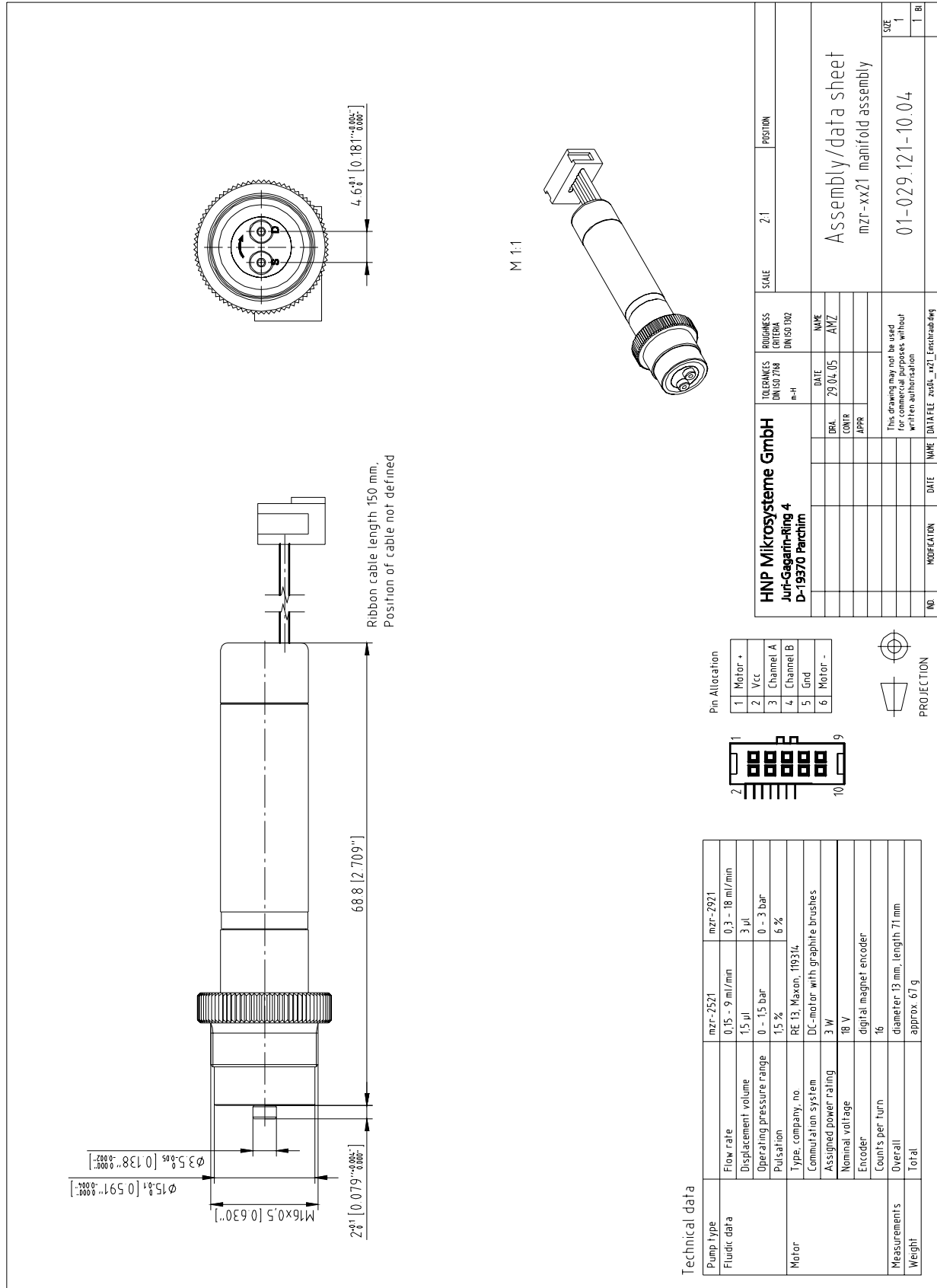

HNP Mikrosysteme GmbH		SCALE		POSITION	
Jur-Gagarin-Ring 4		2:1			
D-19370 Parchim		ASSEMBLY/DATA SHEET		mZR-xx21 manifold assembly	
TOLERANCES		PRECISION		DATE	
DIM ISO 2768		DIM ISO 1927		29.04.05	
m-H		NAME		AMZ	
DATE		DRA		CONTR	
29.04.05		APPR			
This drawing may not be used for commercial purposes without written authorisation		IND		MODIFICATION	
DATA FILE: zustf_xx21_Einschraub.dwg		DATE		01-029.121-10.04	
		NAME		SEE	
				1	
				1 BI	

Pin Allocation

1	Motor +
2	Vcc
3	Channel A
4	Channel B
5	Gnd
6	Motor -

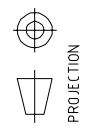
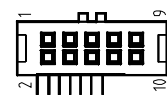

Technical data

Pump type	mZR-2521	mZR-2921
Flow rate	0.15 - 9 ml/min	0.3 - 18 ml/min
Displacement volume	1.5 μ l	3 μ l
Operating pressure range	0 - 1.5 bar	0 - 3 bar
Pulsation	1.5 %	6 %
Type, company, no	RE 13, Maxon, 10934	
Commutation system	DC-motor with graphite brushes	
Assigned power rating	3 W	
Nominal voltage	18 V	
Encoder	digital magnet encoder	
Counts per turn	16	
Overall	diameter: 13 mm, length: 71 mm	
Weight	Total	approx. 67 g

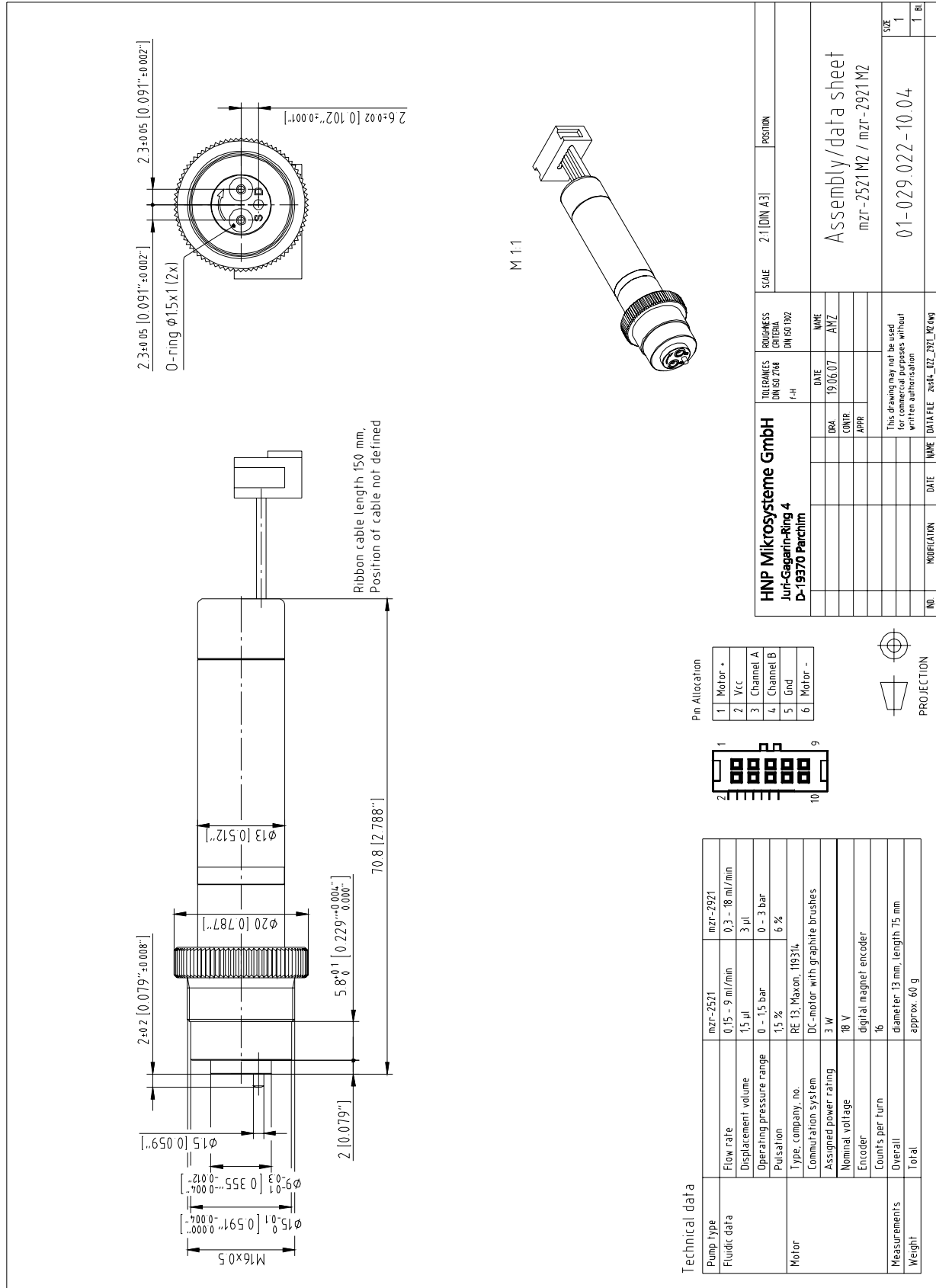

HNP Mikrosysteme GmbH		TOLERANCES		FINISHES		SCALE		POSITION	
Jurt-Gagarin-Ring 4		DIN ISO 2768		DIN ISO 1902		2:1 [DIN A3]			
D-19370 Parching		f-H		f-H					
DATE	19.06.07	NAME	AMZ						
DRW		CONTR							
APPR		Assembly / data sheet							
								mZR-2521M2 / mZR-2921M2	
								01-029-022-10-04	
								SIZE	
								1	
								1 BI	
NO	MODIFICATION	DATE	NAME	DATA FILE	2006_02_29T_MZ.dwg				
This drawing may not be used for commercial purposes without written authorisation.									

